



Leading the World  
in Torque Technology

Measure | Apply | Calibrate | Accessories

# 2010



## Introduction to Torqueleader

We have been a leading manufacturer of Industrial Torque Tools for over 70 years, combining innovative design with precision engineering to produce a comprehensive range of Torque Wrenches, Torque Screwdrivers and Torque Calibration Analysers.

### ABOUT US

- ▶ Torqueleader products are designed, manufactured and assembled in the UK using the latest technology and highly skilled staff. This enables us to maintain complete control of processes, ensuring that we deliver the highest quality tools with a long service life
- ▶ Users of Torqueleader products experience cost savings, through improved efficiency and process control. For example, Torqueleader slipping technology eliminates the operators' influence over the tightening process, delivering consistency and accurate torque control
- ▶ Ongoing success has enabled us to embark on a significant investment in our facilities making sure we continue leading the world in Torque Tool technology

### We are located...

on our own six acre site at:

Tannery Lane, Gosden Common, Bramley,  
Guildford, Surrey GU5 0AJ

### TORQUELEADER CORE VALUES

At Torqueleader we have built our reputation by being committed to the following values:

#### ▶ Innovation

We are committed to designing new, innovative products that deliver you real benefits, such as advanced slipping technology that eliminates overtightening

#### ▶ Precision

The latest CNC technology is used to manufacture our tools to ensure the accuracy and precision necessary to meet today's demanding standards

#### ▶ Performance

Our tools are tested for accuracy, repeatability and durability to ensure that they exceed the performance demanded by you

#### ▶ Solution

We will work with you to overcome problems by developing a custom solution, when standard products are not available

#### ▶ Quality

Quality is the priority at Torqueleader - through providing strong customer service and ensuring that all of our tools are built to the highest standards



For **Tool Selector Guide** see **fold out** flap below ➡

# Tool Selector Guide

Choosing the right tool for your application

# Industrial Sectors

Identifying which tool for which industry

## Maximum Torque (N.m)

Measure	Low Torque Value	<b>TT Dial Measuring Screwdrivers</b> Versatile measuring tools with Track and Peak modes Page 10
	5 N.m	<b>TSD &amp; TWD Digital Torque Screwdrivers and Wrenches</b> Page 15
	20 N.m	<b>ADS Dial Measuring Torque Wrenches</b> Robust tools ideal for Quality Audit Page 11
	40 N.m	<b>BDS Dial Measuring Torque Wrenches</b> Easy to use Quality Audit tools Page 12
	200 N.m	<b>Torcotronic Digital Torque Wrenches</b> Digital wrenches with memory and download capability Page 14
	350 N.m	<b>CDS, DDS &amp; EDS Dial Measuring Torque Wrenches</b> Versatile tools for heavy duty applications Page 13
2000 N.m	High Torque Value	

**Torque Measuring Tools** are primarily used for quality control purposes in a wide range of industrial sectors including Automotive, Aerospace, Electronics, Telecoms and Consumer Products. These tools are recognisable by their dial, scale or digital readout.

From mechanical tools that take basic torque readings to the more sophisticated electronic products that enable the collection, download and analysis of torque data, there is a Torqueleader tool to meet most customer needs.

## Maximum Torque (N.m)

Apply	Torque Value	Preset		Adjustable	
		Low Torque Value	TLS 0022 Torque Limiting Screwdrivers Page 20	PSE 25 Torque Limiting Screwdrivers Page 24	Quickset Calibrated Screwdrivers Page 18
0.25 N.m	1.5 N.m	Minor Torque Limiting Screwdrivers Page 21	PSE 150 Torque Limiting Screwdrivers Page 24	TSC Calibrated Scale Wrenches Page 26	
4 N.m	9 N.m	Standard Torque Limiting Screwdrivers Page 22	PSE 450 Torque Limiting Screwdrivers Page 24	TSC Calibrated Scale Wrenches Page 26	
10 N.m	13.6 N.m	TSP Preset Slipping Torque Wrench Page 27	TBN Breaking Torque Handles Page 28	ATB Adjustable Break Handles Page 30	
25 N.m	70 N.m	TLS 1360 Torque Limiting Screwdrivers Page 23	PSE 1350 Torque Limiting Screwdrivers Page 24	ATB Adjustable Break Handles Page 30	
70 N.m	125 N.m	STB Preset Slipping Torque Breakers Page 25	TSN Preset Slipping Torque Wrenches Page 27	TCS Clicker Wrenches Page 35	
125 N.m	200 N.m	TBN Breaking Torque Handles Page 29	TCP Clicker Wrenches Page 35	TCR Clicker Wrenches Page 34	
200 N.m	400 N.m	TCP Clicker Wrenches Page 35			
400 N.m	750 N.m				
750 N.m	High Torque Value				

**Torque Applying Tools** are used in a manufacturing environment to apply a preset torque to a range of fastening operations in the Automotive, Aerospace, Electronics and Consumer Products industries.

Adjustable torque applying tools are primarily used for maintenance and repair operations in industry in general, where it may be necessary to apply a number of different torque settings to a range of fasteners.

Some of these torque applying tools are also available in enhanced versions including 1000 volt Insulated, Switch (Sw) and Radio Transceiver (RF) options.

## Maximum Torque (N.m)

Calibrate	Low Torque Value	<b>MTP Torque Calibration Analysers</b> Mechanical Screwdriver testers Page 42
	0.1 N.m	<b>ET-cal Compact Torque Calibration Analysers</b> Robust digital torque testers Page 44
	17 N.m	<b>MTS Torque Calibration Analysers</b> Mechanical Screwdriver testers Page 42
	25 N.m	<b>QTC Torque Calibration Analysers</b> Robust workshop digital torque testers Page 43
	1100 N.m	<b>Personal Electronic Torque Analysers</b> PC hosted Calibration System Page 46-49
	2500 N.m	<b>ET-cal Torque Calibration Analysers</b> Robust digital torque testers Page 45
3150 N.m	High Torque Value	

**Torque Calibration Analysis Equipment** compliments our range of Torque Tools available to customers. The mechanical analysers can be used for basic torque adjustment and setting, while the electronic products offer higher accuracy to enable tool calibration and torque data analysis.

While primarily used for Hand Tool testing, some of the analysers also offer the ability to test Power Tools.

## INDUSTRIES WE CATER FOR...

- Torqueleader tools are used worldwide in manufacturing, servicing and quality control sectors
- The industry icons below act as a guide to help you to identify the appropriate tool for your application

Industry Sector	Maintenance and Repair	Manufacturing	Quality Control
Automotive			
Aerospace			
Electronics			
Military			
Utilities			
Consumer Products			
Packaging			

# The 2010 Torqueleader Catalogue

Divided into six clear sections to enable you to find the correct product both quickly and easily.

← For **Tool Selector Guide** see **inside front** cover flap



## Technical Support Info

Information on our services, quality assurance and standards plus a guide to calculating correct torque settings.

Page 2-8



## Torque **Measuring** Tools

Tools that have a scale, dial or digital readout to continually measure torque as it is applied.

Pages 9-16



## Torque **Applying** Tools

Tools that can be set to a required torque value and indicate when that value is achieved.

Pages 17-39



## Torque **Tool Kits**

Examples of custom manufactured kits, designed to meet users' requirements and specifications.

Page 40



## Torque **Calibration** Tools

A versatile range of mechanical and electronic instruments to help customers calibrate, set and measure torque tools.

Pages 41-50



## Torque **Accessories**

A large selection of quality accessories and other equipment for use with Torqueleader wrenches and screwdrivers.

Pages 51-57



For more details please visit us at [www.torqueleader.com](http://www.torqueleader.com)



## Worldwide Distribution

Torqueleader manufactured by MHH Engineering Co. Ltd.

### WORLDWIDE COMMITMENT TO QUALITY OF SERVICE

- Over the past seven decades, we have become a World Leader in the design and manufacture of Torque Tools with our Torqueleader range
- Owned by the Gedore Group, we have the strength of resources to invest for the future ensuring continued customer satisfaction
- Our commitment to our customers is second-to-none. Torqueleader products are available and supported throughout the world
- Our Distributors in over 40 countries are factory trained to give a full service and are able to recommend the best products to meet customers' requirements



Argentina  
Australia  
Austria  
Belgium  
Brazil  
Bulgaria  
Canada  
Chile  
China  
Colombia

Czech Republic  
Denmark  
Egypt  
Estonia  
Finland  
France  
Germany  
Greece  
Hong Kong  
Hungary

India  
Iran  
Ireland  
Israel  
Italy  
Japan  
Korea  
Malaysia  
Mexico  
Netherlands

New Zealand  
Norway  
Poland  
Romania  
Russia  
Singapore  
Saudi Arabia  
Slovakia  
Slovenia  
South Africa

Spain  
Sweden  
Switzerland  
Taiwan  
Thailand  
Turkey  
United Arab Emirates  
United Kingdom  
United States of America





## After Sales Service

Recalibration and Repair of Torqueleader Tools



### CALIBRATION SERVICES

- Torqueleader has a UKAS Accredited Calibration Laboratory **on site**, capable of recalibrating most Hand Torque Tools, Analysers and Transducers in accordance with the International Standards
- If preferred, a Torqueleader Calibration Service is also available at a lower cost
- For more information call us on: +44 (0) 1483 892772, email: [qualityandinspection@torqueleader.co.uk](mailto:qualityandinspection@torqueleader.co.uk) or see our website: [www.torqueleader.com](http://www.torqueleader.com)



No. 0632

### TOOL LUBRICATION INFORMATION

- Like a car, Torqueleader tools contain moving parts that require periodic servicing and lubrication. We recommend a maximum service interval of 12 months, but higher usage applications may need more frequent examination
- This check is part of the standard procedure when any tool is returned to us for service, but if you choose to do your own servicing, the following lubrication table gives details of the recommended oils and greases as used in our tools

### TOOL LUBRICATION TABLE FOR TORQUELEADER PRODUCTS

Lubricants:	Chevron Ploy FM NLGI 2 Temp. Range -20 to 150 C	Fuchs Renolitt CXI 2 Temp. Range -20 to 160 C	Total Multis EP2	Total Multis MS2 Temp. Range -0 to 120 C or equivalent	Silicon Grease RS 555-083 Temp. Range -50 to 200 C	Shell Tonna 32 Lubricating Oil Total Drosera 68	Rocol Dry Moly Paste Lifetime lubrication Max. Temp 450C	NYE Rheolube 386 Strained Grease	WD40 Lubricant / Inhibitor	'3 in 1' Household Lubricating Oil
Dial Wrenches		ADS Ratchet Spindles only	BDS,CDS,DDS &EDS Ratchet Spindles		Window Assm 'O'-rings					
TBN 2 & TBN 10				Spring		Adjusting Screw	Roller & Cam Thrust Pad & Captive Pin			
TBN 25, 65 & 135				Spring		Adjusting Screw	Roller & Cam Thrust Pad & Captive Pin			
TSN Wrenches				General-except Roller, Cam & Ratchet	'O'-rings	Ratchet	Roller & Cam			
TSC/TSP Wrenches						Amalgam of 75% ASP + 25% Oil General Use				
Production Screwdrivers	General Use									
Clean Room Screwdrivers								General Use		
Quickset & Quickset Minor Screwdrivers	General Use	Handle Threads only			'O'-rings					
TT Dial Screwdrivers									Rust Inhibitor on Springs & Spring Clamps	Memory Assembly
MTS, MTP, TCA & DM10/7						Drive Spindle & Needle Bearings				
ISO 1500/90° Calibration Stand	Multiplier & Wormwheel Gearbox									
Push/Pull Gauges	Spring & Spindle									
BTS Pressure Regulators							Adjusting Screw			



## Quality & Standards

### UKAS Certification and Serial Numbers

**Torqueleader**  
MHH Engineering Co.Ltd.  
Bramley, Surrey  
England  
GU5 0AJ  
Tel: 01483 892772  
Email: qualityandinspection@torqueleader.co.uk  
www.torqueleader.com

**Certificate of Calibration**

Model: **QS6 FH** Inspector: **CM** Serial Number: **6BH006938**  
Max. capacity: **6** Ambient temp: **19 °C** Units: **N.m**

Set Torque:	Lower	Upper	Actual Readings				
1	0.94	1.06	1.01	1.043	1.016	1.029	1.012
4	3.76	4.24	4.111	4.09	4.073	3.994	4.003
6	5.64	6.36	6.144	6.183	6.154	6.056	5.99

Calibration complies with the requirements of ISO6789:2003-S  
The uncertainty of measurement of the test equipment used is ±1%

INTERNATIONAL TRACEABILITY THROUGH CALIBRATION LABORATORIES

Tester model: **TD4 ETS & 10N.m TRANSDUCER**

	Transducer	Beam	Weights
Serial No.	14055	-	-
UKAS Cert. No.	146670	-	-
TSD Cert	-	-	-
Laboratory No.	0256	-	-

Date of calibration: 24/02/2009 Head of calibration: D. Gilks

- **Supplier Section** - This can be tailored to include our Distributor's name and address
- **Tool Identification Section** - This is for easy identification of the tool, its maximum capacity and its individual serial number
- **Test Result Section** - This gives the normal point at which the tool was tested, the tolerances and the actual results obtained
- **Standard Section** - This confirms the standard requirements to which the tool complies
- **Note Section** - Information regarding slave pointers etc
- **Traceability Section** - The serial numbers of the test equipment and the route back to National Standards - see diagram below
- **Certification Section** - The date and approval signature of test

### SERIAL NUMBERS

➤ A guide to Torqueleader serial numbers. All new and newly reconditioned Torqueleader tools are now marked with a serial number which enables **Complete Traceability**. This number is stored together with other data such as the original works order number and calibration details

<b>1</b>	<b>B</b>	<b>J</b>	<b>000100</b>
Model Code	Month Code*	Year Code*	Consecutive Serial Number

\*Month Code  
A = January...  
M = December.  
\*Year Code  
A = 2002...  
J = 2010  
K = 2011 etc.

### QUALITY

- All Torqueleader torque equipment is used to assess and improve the quality of our customers' products, enabling their customers to benefit from the assurance that the products will perform satisfactorily over long periods
- At Torqueleader we take the subject of quality seriously - both in the manufacture of Torqueleader tools and in the comprehensive testing of all equipment that we supply

### STANDARDS

- MHH Engineering Co. Ltd. (Manufacturer of Torqueleader tools) is assessed and registered to BS EN ISO 9001:2008 Certificate FM 363. Hand Tools and Implements
- All Torqueleader tools are manufactured to the relevant British and International Engineering Standards
  - All Torqueleader tools conform to the International Standard on Torque Tools ISO 6789:2003 or as specified



### UKAS CERTIFICATION

- Torqueleader's testing and calibration procedures are performed using equipment traceable through UKAS (the United Kingdom Accreditation Service) Accredited Laboratories
- For customers who require a full UKAS Certificate with their tools, this can be provided at an extra cost



# Support

## Quality & Standards

Torqueleader Calibration is Traceable to International Standards

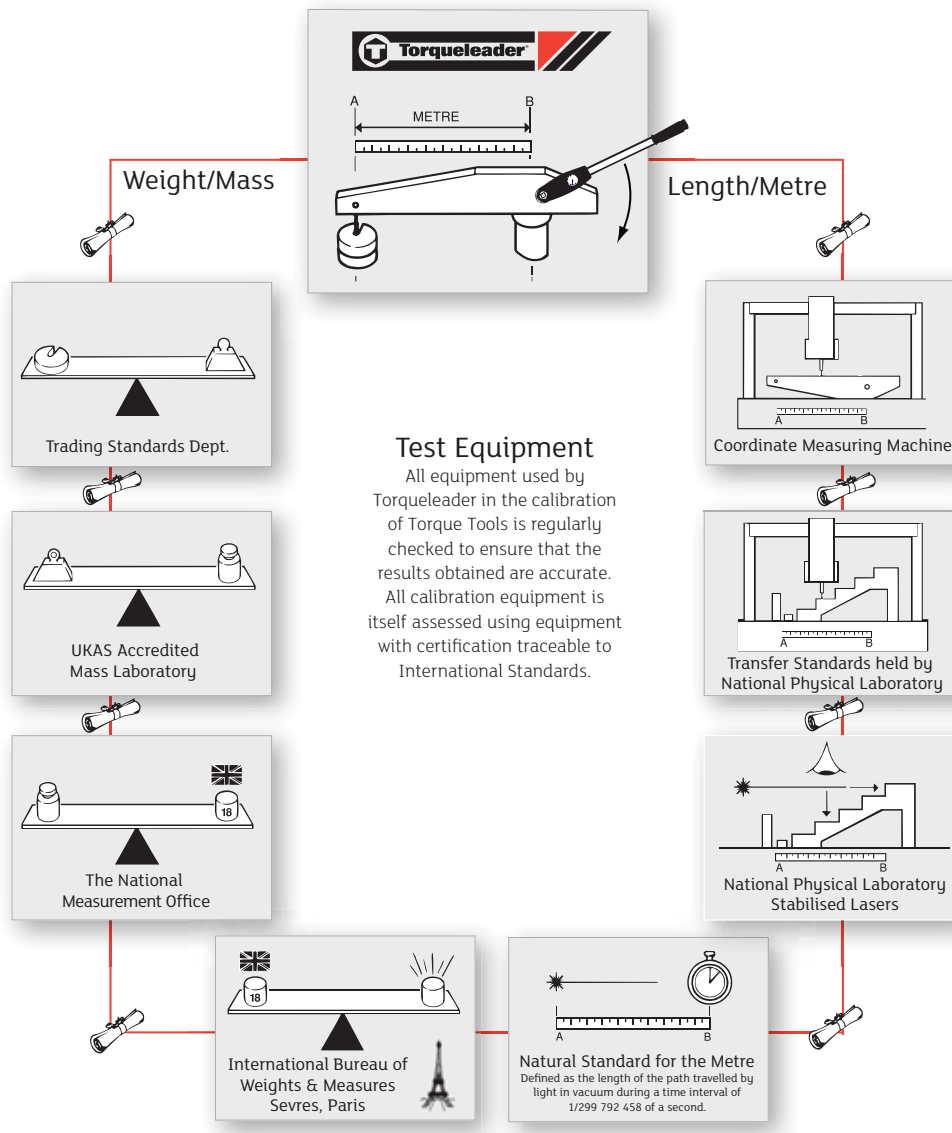

### ACCURACY

#### (Measuring and Calibrated Scale Tools)

- Accuracy is the Torque Tools ability to delivery the torque to the joint as set on the tool's scale, dial or digital display. This is usually expressed as a percentage of the target torque

### RESOLUTION

#### (Measuring and Calibrated Scale Tools)

- Resolution is the number of divisions that the tool's full torque range is divided into. This can be displayed as decimal places on a digital display, number of divisions on a dial or graduations on a scale

### REPEATABILITY

#### (Preset Tools)

- Repeatability is the tool's ability to consistently apply the same torque in subsequent tightening operations. This is usually expressed as a percentage of the preset torque

### ISO 6789:2003

The International Standard for Hand Torque Tools states:

- The effective working range of a tool is from 20% to 100% of its maximum torque value
- The accuracy requirements for Torque Screwdrivers is  $\pm 6\%$  of reading and for Torque Wrenches is  $\pm 4\%$  of reading or  $\pm 6\%$  for Torque Wrenches below 10 N.m
- The maximum torque value for each square drive size
- An overload ability of 125% of maximum torque capacity
- A calibration interval of 5000 cycles or 12 months
- Test and measuring procedures at  $23^\circ \pm 5^\circ\text{C}$
- The maximum permissible uncertainty of measurement of the calibration device shall be  $\pm 1\%$  of the indicated value
- Scale and marking requirements

# An explanation of Torque

Information on measuring Torque

## WHAT IS TORQUE?

- Torque is the application of a **Force** acting at a radial **Distance** and tending to cause rotation
- Torque is used to create tension

## HOW?

- Referring to the diagram below, it can be seen that as the nut and bolt are tightened the two plates are clamped together. The thread converts the applied torque into tension in the bolt shank. The amount of tension created in the bolt is critical

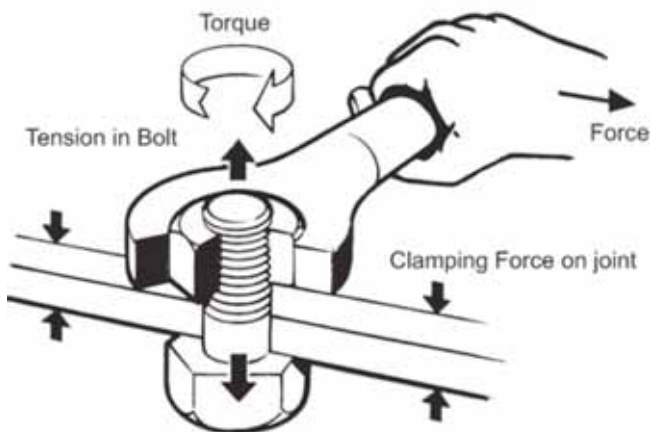

## WHY?

- The tension in the bolt creates a **clamping** force between the two parts. If the clamping force is too low, the fasteners can work loose due to vibration or movement between the component parts. If a clamping force is too high, the fastener may permanently stretch and no longer apply the required clamping force. In severe cases the fastener may fail in assembly or during use when under load. Clamping force is generally referred to as the preload

## HOW IS TORQUE CALCULATED?

- Torque is the result of multiplying the value of **Force** applied by the **Distance** from the point of application
- Comparing the two examples below (A and B) it will be noted that the same resultant torque can be achieved with a lower **Force** if the **Distance** from the nut/bolt is increased

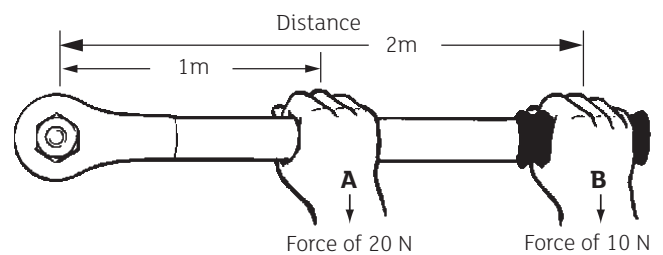

**Let:**

**T** = Torque

**F** = Force

**L** = Length of Lever of Wrench

**Then:**

**T = F x L**

**Example A**

20 Newtons x 1 metre = 20 N.m  
(Newton metres)

**Example B**

10 Newtons x 2 metres = 20 N.m

- It should also be realised that some Torque Wrenches are **length dependent** which means that the actual torque applied to the fastener varies if the hand position on the wrench is varied - even with the wrench preset. This occurs if the pivot point of the wrench mechanism is not coincidental with the point of application of torque



## Torque - Tightening & Conversion Factors

Maximum recommended tightening torques

### RECOMMENDED TIGHTENING TORQUES



Torque N.m

These figures are for guidance only, the torque for each application should be calculated taking into account all circumstances that apply to that joint.

Thread Diameter (mm)	Hex Key Size (mm)	Hex Key Size (mm)	Hex Key Size (mm)	Hex Head Size (mm)
M 2	-	1.5	1.27	4
M 2.5	-	2	1.5	5
M 3	2	2.5	2	5.5
M 4	2.5	3	2.5	7
M 5	3	4	3	8
M 6	4	5	4	10
M 7	-	-	-	11
M 8	5	6	5	13
M 10	6	8	6	17
M 12	8	10	8	19
M 14	-	-	-	22
M 16	-	14	10	24
M 18	-	-	-	27
M 20	-	17	12	30
M 22	-	-	-	32
M 24	-	-	-	36
M 27	-	-	-	-

Bolt Quality		
8.8	10.9	12.7
0.37	0.52	0.63
0.86	1.21	1.45
1.3	1.9	2.3
3.0	4.3	5.1
6.0	8.5	10.2
10.3	14.7	17.9
17.2	24.5	28.4
25.5	35.3	42.2
50.0	70.6	85.3
87.3	123	147
138	194	235
211	299	358
289	412	490
412	579	698
559	785	941
711	1000	1198
1049	1481	1775

### TORQUE CONVERSION FACTORS

Units to be converted	ISO			Imperial			Metric		
	mN.m	cN.m	N.m	ozf.in	lbf.in	lbf.ft	gf.cm	kgf.cm	kgf.m
1 mN.m =	1	0.1	0.001	0.142	0.009	0.0007	10.2	0.01	0.0001
1 cN.m =	10	1	0.01	1.416	0.088	0.007	102	0.102	0.001
1 N.m =	1000	100	1	141.6	8.851	0.738	10 197	10.20	0.102
1 ozf.in =	7.062	0.706	0.007	1	0.0625	0.005	72	0.072	0.0007
1 lbf.in =	113	11.3	0.113	16	1	0.083	1152.1	1.152	0.0115
1 lbf.ft =	1356	135.6	1.356	192	12	1	13 826	13.83	0.138
1 gf.cm =	0.098	0.01	0.0001	0.014	0.0009	0.000 07	1	0.001	0.000 01
1 kgf.cm =	98.07	9.807	0.098	13.89	0.868	0.072	1000	1	0.01
1 kgf.m =	9807	980.7	0.9807	1389	86.8	7.233	100 000	100	1



# Introduction to Torque Measuring Tools

## WHAT ARE THEY USED FOR?

Torque measuring tools are generally used in Research and Development, Inspection and Quality Control where there is a need to check torque settings.

This type of tool can also be used in a Servicing or Production Environment to apply torque.

## WHAT TYPES ARE THERE?

- ▶ Torque measuring tools have a dial or digital readout. They can be a screwdriver or torque wrench design. They enable the operator to read directly from the dial or readout as the torque is applied
- ▶ The torque can be measured as it is applied (**Track mode**) or the maximum torque value can be recorded (**Peak mode**)

## WHAT ARE THE THREE TYPES OF QUALITY AUDITING TEST THAT UTILISE TORQUE MEASURING TOOLS?

- ▶ The **first** of the three tests is the **marking test**. The marking test is used to verify the torque of a previously tightened fastener. This is done by making a clear mark on the surface of the nut, bolt or screw and continuing the mark onto the surface being clamped. This acts as a reference point. The fastener may then be untightened and then retightened until the marks are again **in line**. The torque value can then be read from the torque tool display
- ▶ The **second** of the tests is the **just move test**. Again this test is used to determine the torque setting of a previously tightened fastener. Using a torque measuring tool, a tightening torque is applied to the fastener until movement is just seen or felt. This torque is deemed to be a good indication of the original torque applied to the fastener
- ▶ The **third** and last test is the **break loose test**. The break loose test is another method of checking the torque applied to a previously tightened fastener. Torque is applied in the direction that loosens the fastener, at the point the fastener breaks loose, the torque is recorded. This value is an indication of the torque at which the fastener was originally tightened. This value is typically 20-30% lower than the tightening torque





## TT Dial Measuring Screwdrivers

Versatile measuring tools with Track and Peak modes



- All **TT Dial Measuring Screwdrivers** are designed with easy to read dual scales allowing users to measure both metric and imperial torques
- A versatile tool ideal for use in Quality Control, Research and Development as well as Assembly Operations in industries such as Electronics, White Goods and Consumer Equipment
- All models are capable of measuring torque in either Peak or Track modes. Ideal for establishing torque tightening specifications
- Robust construction utilising stainless steel, tough plastics and anodised aluminium making this tool suitable for most industrial environments
- EPA compliant for use in **electrostatically sensitive applications**
- These tools are designed and manufactured to exceed the requirements of ISO 6789:2003
- Accuracy +/- 6% of reading
- ISO 6789:2003 classification 1D
- Accessories available - see pages 54, 55 and 56



Order Code	Model	Calibrated Range				Drive	k mm	g
		ISO	Imperial	Imperial	Imperial			
017000	TT 50 SD	10-50 cN.m	2 cN.m	14-70 ozf-in	2 ozf-in	1/4	178	190
017400	TT 50 FH	10-50 cN.m	2 cN.m	14-70 ozf-in	2 ozf-in	1/4	178	190
017100	TT 100 SD	20-100 cN.m	5 cN.m	28-140 ozf-in	5 ozf-in	1/4	178	190
017500	TT 100 FH	20-100 cN.m	5 cN.m	28-140 ozf-in	5 ozf-in	1/4	178	190
017200	TT 250 SD	50-250 cN.m	10 cN.m	4-20 lbf-in	0.5 lbf-in	1/2	250	465
017600	TT 250 FH	50-250 cN.m	10 cN.m	4-20 lbf-in	0.5 lbf-in	1/2	250	465
017300	TT 500 SD	100-500 cN.m	20 cN.m	8-40 lbf-in	1 lbf-in	1/2	250	465
017700	TT 500 FH	100-500 cN.m	20 cN.m	8-40 lbf-in	1 lbf-in	1/2	250	465



## ADS Dial Measuring Torque Wrenches

Robust tools ideal for Quality Audit

- **ADS Dial Measuring Torque Wrenches** are constructed from lightweight, robust materials. This combined with an overload protection feature guarantees years of accurate and dependable service
- All models are fitted with double ended ratcheting square drive, allowing torque to be measured or applied in clockwise or anticlockwise directions
- ADS signal wrenches are fitted with an optional audio visual warning device, which alerts the operator when the user set torque has been reached
- A durable storage case is supplied with all ADS wrenches, protecting the tool from damage
- EPA compliant for use in **electrostatically sensitive applications**
- These tools are designed and manufactured to exceed the requirements of ISO 6789:2003
- Accuracy +/- 3% of reading
- ISO 6789:2003 classification 1B
- Designed for ease of repair and recalibration, therefore increasing tool life
- Accessories available - see pages 54, 55 and 57



Order Code	Model	← Calibrated Range →				Drive	mm	kg	Signal
		ISO	للسلسلا	Imperial	للسلسلا				
010100	ADS 4	0.8-4.0 N.m	0.1 N.m	7-35 lbf.in	1 lbf.in	1/4	244	0.52	X
010108	ADS 4 S	0.8-4.0 N.m	0.1 N.m	7-35 lbf.in	1 lbf.in	1/4	244	0.52	✓
010120	ADS 8	1.6-8.0 N.m	0.25 N.m	14-70 lbf.in	1 lbf.in	1/4	244	0.52	X
010128	ADS 8 S	1.6-8.0 N.m	0.25 N.m	14-70 lbf.in	1 lbf.in	1/4	244	0.52	✓
010140	ADS 12 D	2.4-12 N.m	0.5 N.m	24-120 lbf.in	2 lbf.in	1/4	244	0.52	X
010148	ADS 12 DS	2.4-12 N.m	0.5 N.m	24-120 lbf.ft	2 lbf.ft	1/4	244	0.52	✓
010160	ADS 12 A	2.4-12 N.m	0.5 N.m	24-120 lbf.in	2 lbf.in	3/8	244	0.52	X
010168	ADS 12 AS	2.4-12 N.m	0.5 N.m	24-120 lbf.ft	2 lbf.ft	3/8	244	0.52	✓
010180	ADS 25	5-25 N.m	1 N.m	48-240 lbf.in	10 lbf.in	3/8	244	0.52	X
010188	ADS 25 S	5-25 N.m	1 N.m	48-240 lbf.in	10 lbf.in	3/8	244	0.52	✓
010200	ADS 25 F	5-25 N.m	1 N.m	4-20 lbf.in	0.5 lbf.in	3/8	244	0.52	X
010208	ADS 25 FS	5-25 N.m	1 N.m	4-20 lbf.in	0.5 lbf.in	3/8	244	0.52	✓
010220	ADS 40	8-40 N.m	1 N.m	72-360 lbf.in	10 lbf.in	3/8	244	0.52	X
010228	ADS 40 S	8-40 N.m	1 N.m	72-360 lbf.ft	10 lbf.ft	3/8	244	0.52	✓
010240	ADS 40 F	8-40 N.m	1 N.m	6-30 lbf.in	1 lbf.in	3/8	244	0.52	X
010248	ADS 40 FS	8-40 N.m	1 N.m	6-30 lbf.ft	1 lbf.ft	3/8	244	0.52	X



## BDS Dial Measuring Torque Wrenches

Easy to use Quality Audit tools



- **BDS Dial Measuring Torque Wrenches** are constructed from lightweight, robust materials. This combined with an overload protection feature guarantees years of accurate and dependable service
- All models are fitted with double ended ratcheting square drive, allowing torque to be measured or applied in clockwise or anticlockwise directions
- BDS signal wrenches are fitted with an audio visual warning device, which alerts the operator when the user set torque has been reached
- Designed for ease of repair and recalibration, therefore increasing tool life
- A durable storage case (see image below) is supplied with all BDS wrenches, further protecting the tool from damage
- These tools are designed and manufactured to exceed the requirements of ISO 6789:2003
- Accuracy +/- 3% of reading
- ISO 6789:2003 classification 1B
- Accessories available - see page 57

The working principle of Torqueleader Dial Measuring Torque Wrenches

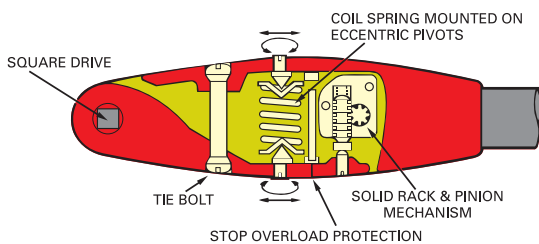

Order Code	Model	← Calibrated Range →			Drive	mm	kg	Signal	
		ISO	Imperial	Imperial					
010300	BDS 80 A	16-80 N.m	2 N.m	12-60 lbf.ft	1 lbf.ft	3/8	435	1.35	X
010380	BDS 80 AS	16-80 N.m	2 N.m	12-60 lbf.ft	1 lbf.ft	3/8	440	1.47	✓
010320	BDS 80 E	16-80 N.m	2 N.m	12-60 lbf.ft	1 lbf.ft	1/2	435	1.36	X
010400	BDS 80 ES	16-80 N.m	2 N.m	12-60 lbf.ft	1 lbf.ft	1/2	440	1.49	✓
010340	BDS 160	32-160 N.m	2.5 N.m	24-120 lbf.ft	2 lbf.ft	1/2	515	1.41	X
010420	BDS 160 S	32-160 N.m	2.5 N.m	24-120 lbf.ft	2 lbf.ft	1/2	520	1.54	✓
010360	BDS 200	40-200 N.m	5 N.m	30-160 lbf.ft	5 lbf.ft	1/2	515	1.41	X
010440	BDS 200 S	40-200 N.m	5 N.m	30-160 lbf.ft	5 lbf.ft	1/2	520	1.54	✓



## CDS, DDS & EDS Torque Wrenches

Versatile tools for heavy duty applications

- **CDS & DDS Dial Measuring Torque Wrenches** are fitted with double ended ratcheting square drive as standard. This allows torque to be measured or applied in clockwise or anticlockwise directions
- CDS, DDS & EDS models are constructed from robust materials. This combined with an overload protection feature guarantees years of accurate and dependable service
- **EDS Dial Measuring Torque Wrenches** are fitted with a double ended 1" fixed square drive for safety when applying high torques
- EDS wrenches are supplied with a two piece handle to allow for easy storage
- Designed for ease of repair and recalibration, therefore increasing tool life
- These tools are designed and manufactured to exceed the requirements of ISO 6789:2003
- Accuracy +/- 3% of reading
- ISO 6789:2003 classification 1B
- Accessories available - see page 57



Order Code	Model	ISO	Calibrated Range			Drive	mm	kg	Signal
			█ █ █ █ █	Imperial	█ █ █ █ █				
010520	CDS 400 S	80-400 N.m	10 N.m	60-300 lbf.ft	10 lbf.ft	3/4	710	3.2	✓
010620	DDS 800 S	160-800 N.m	20 N.m	120-600 lbf.ft	20 lbf.ft	3/4	1000	4.9	✓
010700	EDS 1400 S	280-1400 N.m	25 N.m	200-1000 lbf.ft	25 lbf.ft	1	2040	16.7	✓
010720	EDS 2000 S	400-2000 N.m	50 N.m	300-1500 lbf.ft	50 lbf.ft	1	2040	16.7	✓



## Torcotronic Digital Torque Wrenches

Digital wrenches with memory and download capability



- **Torcotronic Wrenches** are ideal for torque measurement and auditing in Research and Development, Quality Control, Maintenance and Production areas
- Audible and visual alarm signals are activated when approaching or achieving the preset torque
- Bi-directional operations, allows torque to be measured or applied in both clockwise and anticlockwise directions
- Test results can be downloaded into Microsoft Excel via the supplied PC software, allowing full data analysis and storage
- Memory holds up to 2000 data entries
- User modes include Peak, Track and Multi Presets
- The ratchet included can be removed and replaced with standard 9x12 or 14x18 wrench fittings
- Accuracy +/-1% of reading between 10% and 100% of full scale
- ISO 6789:2003 Classification 1E
- Accessories available - call our Sales Hotline **+44 (0) 1483 894476**

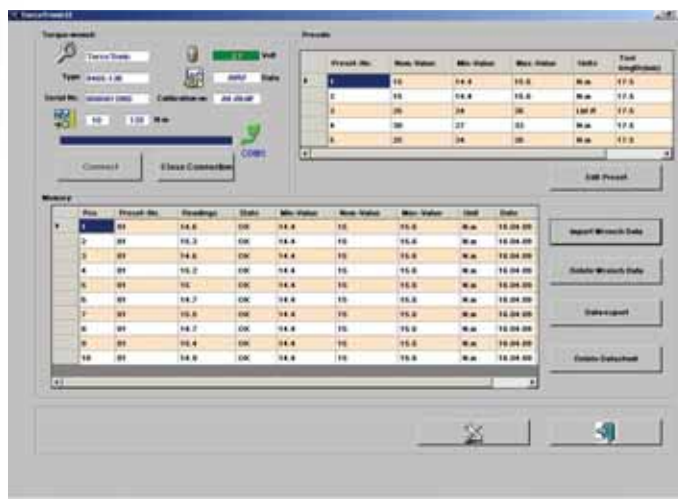

Order Code	Model	← Calibrated Range →		Drive	Adaptors	mm	kg
		ISO	Imperial				
021620	120	10-120 N.m	7-88 lbf.ft	1/2	9x12	435	0.92
021630	350	70-350 N.m	51-258 lbf.ft	1/2	14x18	658	1.34



# TSD & TWD Digital Torque Screwdrivers and Wrenches

- **TSD Digital Torque Screwdrivers and TWD Digital Torque Wrenches** are ideal for torque measurement and auditing in Research and Development, Quality Control, Maintenance and Production areas
- Bi-directional operations allows torque to be applied, measured and recorded in both clockwise and anticlockwise directions
- Up to 99 preset torque and tolerance values can be loaded onto the tool or downloaded from the software provided
- Modes of operation are Track, Peak and Preset
- The reversible ratchet included with the TWD can be removed and replaced with standard 9x12 wrench accessories
- Audible and visual alarm signals are activated when approaching or achieving the preset torque
- RS232 USB connectivity and PC software supplied allows the easy storage and transfer of data to Excel. Download cable and PC software included
- Memory capacity 2000 readings
- User selectable units of measurements including N.m, lbf.in and cN.m
- Accuracy +/-1% of reading between 10% and 100% of full scale
- ISO 6789:2003 classification 1E
- Accessories available - call our Sales Hotline **+44 (0) 1483 894476**



TSD Digital Torque Screwdriver



TWD Digital Torque Wrench



Order Code	Model	← Calibrated Range →				Drive	Adaptors	k mm	↕ kg ↕
		ISO	Resolution	Imperial	Resolution				
020730	TSD 150	15-150 cN.m	0.1 cN.m	1.3-13 lbf.in	0.01 lbf.in	1/4"	A35640	170	0.72
020740	TSD 350	35-350 cN.m	0.1 cN.m	3-30 lbf.in	0.01 lbf.in	1/4"	A35640	170	0.72
020750	TSD 1500	150-1500 cN.m	1 cN.m	13-130 lbf.in	0.1 lbf.in	1/4"	A35640	200	0.77
020762	TWD 20 SB	2-20 N.m	0.01 N.m	1.5-15 lbf.ft	0.01 lbf.ft	1/4"	9x12	410	0.73



## TCM Closure Meters

Designed for Quality Audit in the Packaging Industry



TCM Premium



TCM Standard

- The **TCM Closure Meters** (Standard and Premium models) are designed specifically to accurately measure and record the tightness of screw-on caps on containers, bottles and jars
- Widely used for Quality Audit of bottling and packaging machinery
- The instrument guarantees that quality standards are being met, by ensuring product integrity during storage and distribution. This ensures caps are correctly sealed yet remain easy to open and resealed by the customer
- Clockwise and anticlockwise torque measurement
- The Premium model is fitted with an innovative clamp design which has a clamping capacity of  $\varnothing$  135 mm, designed to grip delicate or unusual shape containers
- The Standard model has a clamping capacity of up to  $\varnothing$  200 mm
- Peak torque function allows the TCM to record the maximum torque values achieved
- Accuracy +/- 4% of reading



Order Code	Model	Calibrated Range				
		ISO		Imperial		
019100	TCM 1 Premium	7-100 cN.m	1 cN.m	10-40 ozf.in	2 ozf.in	6.9
019105	TCM 1	7-100 cN.m	1 cN.m	10-40 ozf.in	2 ozf.in	6.9
019150	TCM 3 Premium	0.2-3.0 N.m	0.05 N.m	2-26 lbf.in	0.5 lbf.in	6.9
019155	TCM 3	0.2-3.0 N.m	0.05 N.m	2-26 lbf.in	0.5 lbf.in	6.9
019200	TCM 5 Premium	0.3-5.0 N.m	0.05 N.m	3-45 lbf.in	0.5 lbf.in	6.9
019205	TCM 5	0.3-5.0 N.m	0.05 N.m	3-45 lbf.in	0.5 lbf.in	6.9
019300	TCM 10 Premium	0.5-10 N.m	0.1 N.m	4-90 lbf.in	1.0 lbf.in	6.9
019305	TCM 10	0.5-10 N.m	0.1 N.m	4-90 lbf.in	1.0 lbf.in	6.9
019400	TCM 15 Premium	1-15 N.m	0.2 N.m	4-132 lbf.in	2.0 lbf.in	6.9
019405	TCM 15	1-15 N.m	0.2 N.m	4-132 lbf.in	2.0 lbf.in	6.9



# Introduction to Torque Applying Tools

## WHAT ARE THEY USED FOR?

Torque applying tools are used to apply a set torque to a fastener. The tool will slip, break or click to signal to the operator when the set torque is reached

## WHAT TYPES ARE THERE?

- ▶ **Preset Tools** are ideal in environments that require the same torque to be applied to a fastener time after time. These types of tool are tamperproof so are ideal for use by staff who are not highly skilled. The tools must be set using a Calibration Analyser
- ▶ **Calibrated Scale Tools** have a visible scale that allows the user to adjust the tools to their desired torque setting. This tool is ideal for use in areas where a range of different torque settings need to be applied



## DIFFERENT TORQUE TOOL MECHANISMS

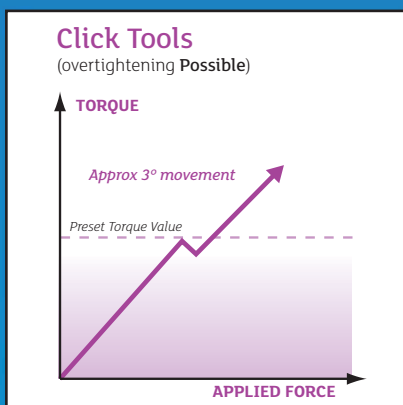

**Click Tools** When the preset torque value is reached the operator will hear a **click**, feel an impulse and there will be approximately 3° of tool movement. Resetting takes place when the hand pressure is released. Work can then immediately continue. These tools are length dependent – the position of the hand on the tool alters the torque produced. Continued application of force after the 3° of movement will cause the torque applied to increase above the required preset limit.



**Overtightening Possible**

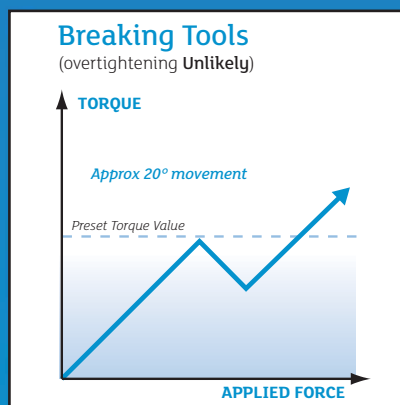

**Breaking Tools** When the preset torque value is reached, these tools **break** at a specific point along the tool's length – usually at a pivot point near the tool's head. In most cases the movement is approximately 20°. The tool is automatically reset by allowing the handle to return to its **in line** position. These tools are length dependent, with hand position altering the torque applied. Continued application of force after 20° of tool movement will increase the torque applied above the preset limit but with the greater angle of tool movement this is less likely.



**Overtightening Unlikely**

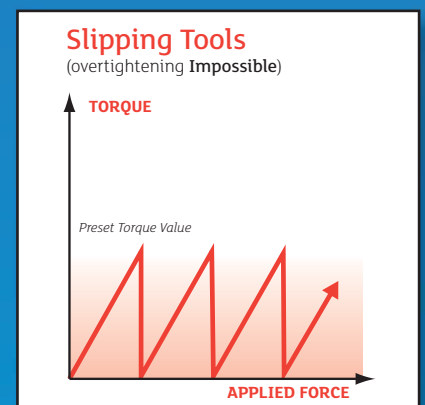

**Slipping Tools** When the preset torque value is reached, a mechanism in the tool causes the application of torque to cease and the tool **slips** free for a short time until resetting occurs. Even if the application of force is repeated, the preset torque value will not be exceeded, therefore making it impossible to overtighten a fastener. These tools are **not** length dependent.



**Overtightening Impossible**



# Apply



## Quickset Calibrated Screwdrivers

Versatile slipping tools with calibrated scale



- ▶ The **Quickset Calibrated Screwdrivers** range incorporates slipping technology, eliminating overtightening completely
- ▶ Micrometer adjustment allows easy accurate setting of a range of torques, ideal for use in a Service or Repair environment
- ▶ Smooth reset action reduces operator fatigue
- ▶ These tools are designed and manufactured to exceed the requirements of ISO 6789:2003
- ▶ Calibrated in clockwise direction. Anticlockwise calibration on request
- ▶ Accuracy +/- 6% of setting
- ▶ ISO 6789:2003 classification 2D
- ▶ Accessories available - see pages 54, 55 and 56

Order Code	Model	← Calibrated Range →		Drive	k mm	g
		Range	السلسلسا			
016000	Quickset Minor Metric SD	20-120 cN.m	1 cN.m		160	158
016040	Quickset Minor Metric FH	20-120 cN.m	1 cN.m		169	165
016020	Quickset Minor Imp SD	20-120 ozf.in	1 ozf.in		160	158
016060	Quickset Minor Imp FH	20-120 ozf.in	1 ozf.in		169	165
016080	Quickset Minor lbf.in SD	2-12 lbf.in	0.1 lbf.in		160	158
016070	Quickset Minor lbf.in FH	2-12 lbf.in	0.1 lbf.in		169	165
016100	Quickset 6* SD	1-6 N.m	0.1 N.m		222	340
016500	Quickset 6* FH	1-6 N.m	0.1 N.m		184	334
016200	Quickset 50* SD	5-50 lbf.in	1 lbf.in		222	340
016600	Quickset 50* FH	5-50 lbf.in	1 lbf.in		184	335
016300	Quickset 9* SD	4-9 N.m	0.1 N.m		222	340
016700	Quickset 9* FH	4-9 N.m	0.1 N.m		184	335
016400	Quickset 80* SD	40-80 lbf.in	1 lbf.in		222	340
016800	Quickset 80* FH	40-80 lbf.in	1 lbf.in		184	335

\*Supplied with sliding T-Bar



# Ergo Quickset Calibrated Screwdrivers

Slipping technology in compact ergonomic tools

- The **Ergo Quickset Calibrated Screwdrivers** range incorporates slipping technology, eliminating overtightening
- A specially designed ergonomic grip combined with a smooth reset action reduces operator fatigue
- Once the tool is set, the adjustment lock prevents accidental tool adjustment, therefore ensuring the correct torque is applied
- EPA compliant for use in **electrostatically sensitive applications**
- These tools are designed and manufactured to exceed the requirements of ISO 6789:2003
- Calibrated in clockwise direction. Anticlockwise calibration on request
- Accuracy +/- 6% of setting
- ISO 6789:2003 classification 2D
- Accessories available - see pages 54, 55 and 56



Order Code	Model	← Calibrated Range →		Drive	mm	g
		Range				
060700	QSN 40 FH	5-40 cN.m	1 cN.m		159	124
060900	QSN 40 SD	5-40 cN.m	1 cN.m		159	124
060740	QSA 60 FH	10-60 ozf.in	1 ozf.in		159	124
060940	QSA 60 SD	10-60 ozf.in	1 ozf.in		159	124
060720	QSA 4 FH	0.5-4 lbf.in	0.1 lbf.in		159	124
060920	QSA 4 SD	0.5-4 lbf.in	0.1 lbf.in		159	124
060100	QSN 120 FH	20-120 cN.m	1 cN.m		183	230
060200	QSN 120 SD	20-120 cN.m	1 cN.m		183	230
060140	QSA 160 FH	20-160 ozf.in	1 ozf.in		183	230
060240	QSA 160 SD	20-160 ozf.in	1 ozf.in		183	230
060120	QSA 12 FH	2-12 lbf.in	0.1 lbf.in		183	230
060220	QSA 12 SD	2-12 lbf.in	0.1 lbf.in		183	230
060300	QSN 600* FH	1-6 N.m	0.1 N.m		196	335
060400	QSN 600* SD	1-6 N.m	0.1 N.m		196	335
060320	QSA 50* FH	10-50 lbf.in	1 lbf.in		196	335
060420	QSA 50* SD	10-50 lbf.in	1 lbf.in		196	335
060500	QSN 900* FH	4-9 N.m	0.1 N.m		196	335
060600	QSN 900* SD	4-9 N.m	0.1 N.m		196	335
060520	QSA 80* FH	30-80 lbf.in	1 lbf.in		196	335
060620	QSA 80* SD	30-80 lbf.in	1 lbf.in		196	335



# Apply



## Torque Limiting Screwdrivers

Slipping technology in compact production tools



- The **TLS 0022** incorporates slipping technology, eliminating overtightening
- Tamperproof adjustment makes this presetable tool ideal for Production, where the same torque must be accurately and repeatably applied
- Tool must be preset on a Calibration Analyser
- Smooth reset action reduces operator fatigue
- CRS version for use in Clean Rooms rate to class 100
- One way (O/W) versions enable fasteners to be both torqued or loosened
- Designed and manufactured to exceed the requirements of ISO 6789:2003
- Accuracy +/- 6% of setting
- ISO 6789:2003 classification 2F
- Accessories available - see pages 54 and 56

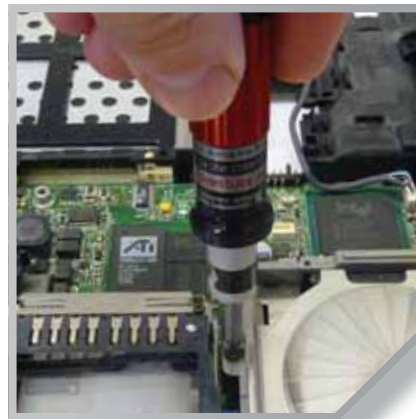

Order Code	Model	Range		Drive	k mm	g	Colour
		ISO	Imperial				
015000	TLS 0022 Micro	2-22 cN.m	3-32 ozf.in		76	50	Red
015080	TLS 0022	0.5-22 cN.m	0.7-32 ozf.in		104	72	Gold
015085	TLS 0022 O/W	0.5-22 cN.m	0.7-32 ozf.in		116	85	Gold
015089*	CRS 100-0022 FH	2-22 cN.m	3-32 ozf.in		104	72	Grey

\*Clean Room version



## Torque Limiting Screwdrivers

Slipping technology in compact production tools

- The **Minor Screwdrivers** incorporate slipping technology, eliminating overtightening
- Tamperproof adjustment makes this tool presettable ideal for Production, where the same torque must be accurately and repeatably applied
- Tool must be preset on a Calibration Analyser
- Smooth reset action reduces operator fatigue
- CRS version for use in Clean Rooms rate to class 100
- One way (O/W) versions enable fasteners to be both torqued or loosened
- Impact Free Reset versions are available upon request
- Designed and manufactured to exceed the requirements of ISO 6789:2003
- Repeatability +/- 6% of setting
- ISO 6789:2003 classification 2F
- Accessories available - see pages 54, 55 and 56



Order Code	Model	Range		Drive	mm	g	Colour
		ISO	Imperial				
015100	Minor SD	2-135 cN.m	0.8 - 12 lbf.in	1/4	143	210	Blue
015105	Minor SD O/W	2-135 cN.m	0.8 - 12 lbf.in	1/4	143	210	Blue
015200	Minor FH	2-135 cN.m	0.8 - 12 lbf.in	3/8	111	210	Blue
015205	Minor FH O/W	2-135 cN.m	0.8 - 12 lbf.in	3/8	125	210	Blue
015120	Minor SD	2-135 cN.m	0.8 - 12 lbf.in	1/4	143	210	Green
015125	Minor SD O/W	2-135 cN.m	0.8 - 12 lbf.in	1/4	143	210	Green
015220	Minor FH	2-135 cN.m	0.8 - 12 lbf.in	3/8	111	210	Green
015225	Minor FH O/W	2-135 cN.m	0.8 - 12 lbf.in	3/8	125	210	Green
015140	Minor SD	2-135 cN.m	0.8 - 12 lbf.in	1/4	143	210	Red
015145	Minor SD O/W	2-135 cN.m	0.8 - 12 lbf.in	1/4	143	210	Red
015240	Minor FH	2-135 cN.m	0.8 - 12 lbf.in	3/8	111	210	Red
015245	Minor FH O/W	2-135 cN.m	0.8 - 12 lbf.in	3/8	125	210	Red
015160	Minor SD	2-135 cN.m	0.8 - 12 lbf.in	1/4	143	210	Gold
015165	Minor SD O/W	2-135 cN.m	0.8 - 12 lbf.in	1/4	143	210	Gold
015260	Minor FH	2-135 cN.m	0.8 - 12 lbf.in	3/8	111	210	Gold
015265	Minor FH O/W	2-135 cN.m	0.8 - 12 lbf.in	3/8	125	210	Gold
015209*	CRS 100-0135	11-135 cN.m	1-12 lbf.in	3/8	111	210	Grey

\*Clean room version



# Apply



## Torque Limiting Screwdrivers

Slipping technology in compact production tools



- ▶ The **Standard Screwdrivers** incorporate slipping technology, eliminating overtightening
- ▶ The easy to set, tamperproof adjustment makes this presetable tool ideal for Production, where the same torque must be accurately and repeatably applied
- ▶ Tools must be preset on a Calibration Analyser
- ▶ Smooth reset action reduces operator fatigue
- ▶ CRS version for use in Clean Rooms rate to class 100
- ▶ One way (O/W) versions enable fasteners to be both torqued or loosened
- ▶ Impact Free Reset versions are available upon request
- ▶ Designed and manufactured to exceed the requirements of ISO 6789:2003
- ▶ Repeatability +/- 6% of setting
- ▶ ISO 6789:2003 classification 2F
- ▶ Accessories available - see pages 54, 55 and 56

Order Code	Model	Range		Drive	k mm	g	Colour
		ISO	Imperial				
015500	Standard SD	6-406 cN.m	0.5-36 lbf.in		159	280	Blue
015505	Standard SD O/W	6-406 cN.m	0.5-36 lbf.in		159	280	Blue
015600	Standard FH	6-406 cN.m	0.5-36 lbf.in		127	280	Blue
015605	Standard FH O/W	6-406 cN.m	0.5-36 lbf.in		127	280	Blue
015520	Standard SD	6-406 cN.m	0.5-36 lbf.in		159	280	Green
015525	Standard SD O/W	6-406 cN.m	0.5-36 lbf.in		159	280	Green
015620	Standard FH	6-406 cN.m	0.5-36 lbf.in		127	280	Green
015625	Standard FH O/W	6-406 cN.m	0.5-36 lbf.in		127	280	Green
015540	Standard SD	6-406 cN.m	0.5-36 lbf.in		159	280	Red
015545	Standard SD O/W	6-406 cN.m	0.5-36 lbf.in		159	280	Red
015640	Standard FH	6-406 cN.m	0.5-36 lbf.in		127	280	Red
015645	Standard FH O/W	6-406 cN.m	0.5-36 lbf.in		127	280	Red
015560	Standard SD	6-406 cN.m	0.5-36 lbf.in		159	280	Gold
015565	Standard SD O/W	6-406 cN.m	0.5-36 lbf.in		159	280	Gold
015660	Standard FH	6-406 cN.m	0.5-36 lbf.in		127	280	Gold
015665	Standard FH O/W	6-406 cN.m	0.5-36 lbf.in		127	280	Gold
015609*	CRS 100-0406	16-406 cN.m	1.4-36 lbf.in		127	280	Grey

\*Clean Room version



# Torque Limiting Screwdrivers

Slipping technology in compact production tools

- ▶ The **TLS 1360** incorporates slipping technology, eliminating over torque
- ▶ Tamperproof adjustment makes this presetable tool ideal for Production, where the same torque must be accurately and repeatably applied
- ▶ Tools must be preset on a Calibration Analyser
- ▶ Smooth reset action combined with the supplied T-Bar to increase leverage reducing operator fatigue
- ▶ CRS version for use in Clean Rooms rate to class 100
- ▶ One way (O/W) versions enable fasteners to be both torqued or loosened
- ▶ Impact Free Reset versions are available upon request
- ▶ Designed and manufactured to exceed the requirements of ISO 6789:2003
- ▶ Repeatability +/- 6% of setting
- ▶ ISO 6789:2003 classification 2F
- ▶ Accessories available - see pages 54, 55 and 56



**NEW**  
Colour  
Options for  
**2010**

Order Code	Model	Range		Drive	mm	g	Colour
		ISO	Imperial				
015840	TLS 1360 SD	1-13.6 N.m	10-120 lbf.in	1/4	168	325	Blue
015845	TLS 1360 SD O/W	1-13.6 N.m	10-120 lbf.in	1/4	168	325	Blue
015890	TLS 1360 FH	1-13.6 N.m	10-120 lbf.in	3/8	168	325	Blue
015895	TLS 1360 FH O/W	1-13.6 N.m	10-120 lbf.in	3/8	168	325	Blue
015810	TLS 1360 SD	1-13.6 N.m	10-120 lbf.in	1/4	168	325	Green
015815	TLS 1360 SD O/W	1-13.6 N.m	10-120 lbf.in	1/4	168	325	Green
015860	TLS 1360 FH	1-13.6 N.m	10-120 lbf.in	3/8	168	325	Green
015865	TLS 1360 FH O/W	1-13.6 N.m	10-120 lbf.in	3/8	168	325	Green
015820	TLS 1360 SD	1-13.6 N.m	10-120 lbf.in	1/4	168	325	Red
015825	TLS 1360 SD O/W	1-13.6 N.m	10-120 lbf.in	1/4	168	325	Red
015870	TLS 1360 FH	1-13.6 N.m	10-120 lbf.in	3/8	168	325	Red
015875	TLS 1360 FH O/W	1-13.6 N.m	10-120 lbf.in	3/8	168	325	Red
015900	TLS 1360 SD	1-13.6 N.m	10-120 lbf.in	1/4	168	325	Black
015905	TLS 1360 SD O/W	1-13.6 N.m	10-120 lbf.in	1/4	168	325	Black
015920	TLS 1360 FH	1-13.6 N.m	10-120 lbf.in	3/8	137	325	Black
015925	TLS 1360 FH O/W	1-13.6 N.m	10-120 lbf.in	3/8	137	325	Black
015939*	CRS 100-1360 FH	1.35-13.6 N.m	12 -120 lbf.in	3/8	137	325	Grey

\*Clean Room version



# Apply



## PSE Production Torque Screwdrivers

Slipping production tools with ergonomic design



- The **PSE Screwdrivers** range incorporates slipping technology, eliminating overtightening
- A specially designed ergonomic grip combined with a smooth reset action reduces operator fatigue
- The easy to set, tamperproof adjustment makes this tool ideal for Production, where the same torque must be accurately and repeatably applied
- Tool must be preset on a Calibration Analyser
- PSE 1350 is supplied with a T-Bar
- EPA compliant for use in **electrostatically sensitive applications**
- These tools are designed and manufactured to exceed the requirements of ISO 6789:2003
- Repeatability +/- 6% of setting
- ISO 6789:2003 classification 2F
- Accessories available - see pages 54 and 56

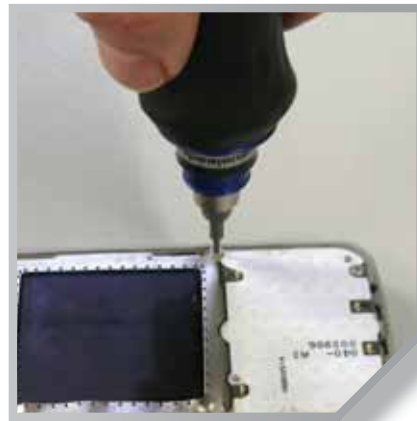

Order Code	Model	Range	Drive	↳ mm ↲	↳ g ↲
062200	PSE 25 FH	0.5-25 cN.m	⊕ <sub>1/4</sub>	116	91
062400	PSE 150 FH	2-150 cN.m	⊕ <sub>1/4</sub>	121	185
062600	PSE 450 FH	6-450 cN.m	⊕ <sub>1/4</sub>	121	202
062800	PSE 1350 FH	1-13.5 N.m	⊕ <sub>1/4</sub>	121	229



## STB Preset Slipping Torque Breakers

Slipping production tools ideal for hydraulic applications

- The **STB Slipping Torque Breakers** provide a multiple slip action to eliminate overtightening of pipe fittings, hydraulic connectors and other applications where wrench fittings are used
- The STB allows the use of interchangeable wrench attachments
- The tool slips 110° before automatically resetting **in line**, preventing overtightening
- Ideal for use in hydraulic pipe work and heating system applications where open end or flare end wrenches are necessary
- Tool must be preset on a Calibration Analyser
- The STB is available with Electrical Switch (Sw) and Radio Frequency (RF) transceiver options to interface with a PLC etc (see pages 36-38)
- Designed and manufactured to ISO 6789:2003
- Repeatability +/- 4% of setting
- ISO 6789:2003 classification 2C
- Accessories available - see page 54



Order Code	Model	Range		Drive	mm	g
		ISO	Imperial			
052000	STB 35	7-35 N.m	5-25 lbf.ft	16	225	490
052010	STB 35 G	7-35 N.m	5-25 lbf.ft	9x12	245	460
052100	STB 70	20-70 N.m	14-51 lbf.ft	16	365	910
052110	STB 70 G	20-70 N.m	14-51 lbf.ft	9x12	355	880



## TSC Calibrated Scale Wrenches

Slipping tools designed for Service and Repair



- **TSC Calibrated Wrenches** incorporate Torqueleader's unique slipping technology, eliminating overtightening
- The wrenches are non length dependent, giving accurate repeatability regardless of where the tool is held
- The micrometer style scale allows precise adjustment resulting in better accuracy. The built in adjustment lock prevents accidental adjustment
- Designed to operate in any environment from the toughest Production line to the most delicate Electronic Assembly area
- EPA compliant for use in **electrostatically sensitive applications**
- Designed and manufactured to exceed the requirements of ISO 6789:2003
- Accuracy +/- 6% of setting
- ISO 6789:2003 classification 2A
- Accessories available - see pages 54 and 55



Order Code	Model	← Calibrated Range →		Drive	L mm	g
		Range	Scale			
056020	TSC 5	1-5 N.m	0.05 N.m	1/4"	195	235
056040	TSC 10	2-10 N.m	0.1 N.m	1/4"	195	235
056060	TSC 45	10-45 lbf.in	0.5 lbf.in	1/2"	195	235
056080	TSC 90	20-90 lbf.in	1.0 lbf.in	1/2"	195	235



## TSN & TSP Preset Slipping Wrenches

Slipping tools that ensure joint integrity

- The **TSN and TSP Torque Wrenches** slip free when predetermined torque setting is reached, completely eliminating overtightening
- Ratchet design ensures smooth positive torque control
- The TSN and TSP wrenches are non length dependent, giving accurate repeatability regardless of where the tool is held
- Robust construction, built to withstand industrial environments, guaranteeing long service life
- TSN and TSP wrenches are available with Electrical Switch (Sw) or Radio Frequency (RF) transceiver options to interface with a PLC etc (see pages 36-38)
- One way options for tightening and loosening fasteners (no ratchet) – call our Sales Hotline on **+44 (0) 1483 894476**
- EPA compliant for use in **electrostatically sensitive applications**
- Designed and manufactured to exceed the requirements of ISO 6789:2003
- Repeatability +/- 4% of setting for tools above 10 N.m and +/- 6% of setting for tools below 10 N.m
- ISO 6789:2003 classification 2C
- Accessories available - see pages 54 and 55

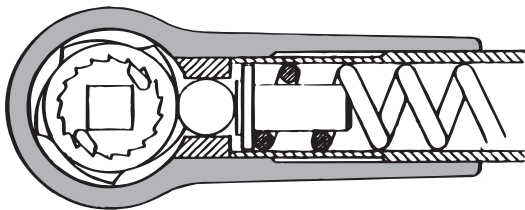

Working principle of the Torqueleader Slipping Wrenches

Order Code	Model	Range		Drive	mm	kg
		ISO	Imperial			
056090	TSP 5	1-5 N.m	10-45 lbf.in	1/4	185	0.19
056100	TSP 10	2-10 N.m	20-90 lbf.in	1/4	185	0.19
011017	TSN 25 D	3-25 N.m	2-18 lbf.ft	1/4	216	0.34
011019	TSN 25 A	3-25 N.m	2-18 lbf.ft	3/8	216	0.34
011035	TSN 55	15-55 N.m	10-40 lbf.ft	3/8	324	0.80
011055	TSN 125	40-125 N.m	30-90 lbf.ft	1/2	460	1.36



## TBN Breaking Torque Handles

Compact production tools



- ▶ The **TBN Breaking Torque Handles** range utilises a 20° breaking action that reduces the possibility of overtightening by clearly indicating to the operator when the preset torque has been achieved
- ▶ Removable collar allows up to 90° degree break angle further reducing the possibility of over torque
- ▶ The bi-directional tools are designed to operate in any environment from the toughest Production line to the most delicate Electronic Assembly areas
- ▶ Tool requires presetting on a Calibration Analyser
- ▶ The TBN range is available with a variety of end fitting styles. Electrical Switch (Sw) and Radio Frequency (RF) versions are also available (see pages 36-38) to interface with a PLC etc
- ▶ TBN tools are ideal for tightening SMA connectors/ cable terminations
- ▶ These tools are not issued with a Calibration Certificate unless supplied preset and fitted with suitable end fittings
- ▶ EPA compliant for use in **electrostatically sensitive applications**
- ▶ Designed and manufactured to exceed the requirements of ISO 6789:2003
- ▶ Repeatability +/- 6% of setting
- ▶ ISO 6789:2003 classification 2C
- ▶ Accessories available - see page 53

Order Code	Model	← Range →		Drive	mm	g
		ISO	Imperial			
011100	TBN 2	0.2-2 N.m	1.8-18 lbf.in	Captive Pin	105	110
011110	TBN 2 G	0.2-2 N.m	1.8-18 lbf.in		133	125
011200	TBN 10	1-10 N.m	9-89 lbf.in	Captive Pin	105	130
011210	TBN 10 G	1-10 N.m	9-89 lbf.in		133	145



# TBN Breaking Torque Handles

Robust production tools

- The **TBN Breaking Torque Handles** range utilises a 20° breaking action that reduces the possibility of overtightening by clearly indicating to the operator when the preset torque has been achieved
- The TBN's precision mechanism ensures that the set torque is applied consistently, delivering excellent repeatability making certain our customers' quality objectives are met
- Robust construction built to withstand the harshest industrial environment, guaranteeing long service life
- The TBN range is available with a variety of end fitting styles. Electrical Switch (Sw) and Radio Frequency (RF) versions are also available to interface with a PLC etc. (see pages 36-38)
- These tools are designed and manufactured to exceed the requirements of ISO 6789:2003
- Repeatability +/- 4% of setting
- ISO 6789:2003 classification 2C
- Accessories available - see page 54



TBN G Model

Order Code	Model	← Range →		Drive	mm	kg
		ISO	Imperial			
050000	TBN 25	5-25 N.m	4-18 lbf.ft	16	265	0.41
050010	TBN 25 G	5-25 N.m	4-18 lbf.ft	9x12	265	0.41
050100	TBN 65	10-65 N.m	7-48 lbf.ft	16	302	0.75
050110	TBN 65 G	10-65 N.m	7-48 lbf.ft	9x12	302	0.75
050200	TBN 135	20-135 N.m	15-100 lbf.ft	16	408	1.03
050210	TBN 135 G	20-135 N.m	15-100 lbf.ft	9x12	408	1.03
050300	TBN 200	40-200 N.m	29-147 lbf.ft	16	520	1.40
050310	TBN 200 G	40-200 N.m	29-147 lbf.ft	9x12	520	1.40



## ATB Adjustable Breaking Wrenches

Calibrated scale tools designed for Service and Repair



**NEW**  
Product for  
**2010**

- The **ATB Breaking Wrenches** utilise a 20° breaking action, which very clearly signals to the operator when the desired torque has been reached therefore vastly reducing the possibility of over torque
- The adjustment range ensures the tool is suitable for a variety of applications across multiple industries from Aviation Maintenance to General Repair tasks
- The micrometer style scale allows quick, precise adjustment while the adjuster lock prevents accidental adjustment during use, ensuring accuracy is maintained
- The robust construction ensures the tool is tough enough for use in all environments
- Designed and manufactured to exceed the requirements of ISO 6789:2003
- Accuracy +/- 4% of setting
- ISO 6789:2003 classification 2A
- Accessories available - see page 54



ATB 25 I  
lbf.in



ATB 25 F  
lbf.ft

Order Code	Model	← Calibrated Range →				Drive	mm	g
		ISO	Imperial	Imperial	Imperial			
050600	ATB 25	5-25 N.m	1 N.m	–	–	16 Spigot	297	678
050605	ATB 25 I	–	–	40-220 lbf.in	10 lbf.in	16 Spigot	297	678
050610	ATB 25 F	–	–	4-18 lbf.ft	1 lbf.ft	16 Spigot	297	678
050620	ATB 25 G	5-25 N.m	1 N.m	–	–	9x12 Carrier rectangular fitting	303	700
050625	ATB 25 G	–	–	40-220 lbf.in	10 lbf.in	9x12 Carrier rectangular fitting	303	700
050630	ATB 25 G	–	–	4-18 lbf.ft	1 lbf.ft	9x12 Carrier rectangular fitting	303	700



## Weld Stud Test Tools

Go/No Go testers for weld stud integrity

- The **Weld Stud Test Tools** are designed for a quick and easy controlled test of the integrity of welds holding threaded studs onto sheet metal
- Bi-directional tool enabling 20° of movement, utilising Torqueleader breaking technology
- Designed with no scale, the tool must be preset on a Torque Analyser. This removes the possibility of unauthorized adjustment during use
- Ideal for use in Production and Quality Control environments
- A range of end fittings are available for use with most popular weld stud thread sizes and lengths

Order Code	Model	← Calibrated Range →		mm	g
		ISO	Imperial		
055000	WSTT 10	1-10 N.m	9-90 lbf.in	215	120
055010	WSTT 20	4-20 N.m	35-180 lbf.in	320	220

### Metric End Order For Tool Ranges

WSTT 10 Order Code	WSTT 20 Order Code	Weld Stud Thread x Maximum Length
055020		M2.5 x 25
055025		M3 x 50
055030		M4 x 50
055035	055050	M5 x 50
055040	055055	M6 x 50
055045	055060	M8 x 50
	055065	M10 x 75
	055070	M12 x 75

### Imperial End Order Codes For Tool Ranges

WSTT 10 Order Code	WSTT 20 Order Code	Weld Stud Thread x Maximum Length
055075		4-40 x 1.5"
055080		6-32 x 2"
055085		8-32 x 2"
055090	055105	10-32 x 2.5"
055095	055110	10-24 x 2.5"
055100	055115	1/4-20 x 4"
	055120	5/16-18 x 4"
	055125	3/8-16 x 4"



Order Code	Description
055000	Weld Stud Test Tool Setting Adaptor Blank



## 1000V Insulated Tools

Tools for use in high voltage applications



- The **TSN I** and **TBN I** range of **Insulated Torque Wrenches** protect against voltages up to 1000V making these tools ideal for use in **electrically live** situations, in a wide range of industries
- The TSN I design incorporates slipping technology, eliminating the chances of overtightening
- The TBN I design incorporates breaking technology reducing the chance of overtightening
- Pin retention guarantees socket security
- These tools can only be **supplied factory preset**. TBN models must have the wrench fitting factory fitted
- Designed and manufactured to comply with the requirements of BS EN ISO 6789:2003
- Tools come complete with a Certificate to BS EN 60900:2004 (Live working hand tools for use up to 1000V ac and 1500V dc)
- Repeatability +/- 4% of set torque (TSN range) and repeatability +/- 6% of set torque (TBN range)
- Insulated sockets available – see page 55

Order Code	Model	Range		Drive	mm	kg
		ISO	Imperial			
011109	TBN 2 I	0.2-2 N.m	1.8-18 lbf.in	–	125	0.4
011209	TBN 10 I	1.0-10 N.m	9-89 lbf.in	–	125	0.4
011004	TSN 25D I	3-25 N.m	2-18 lbf.ft	1/4	220	0.4
011014	TSN 25A I	3-25 N.m	2-18 lbf.ft	3/8	220	0.4
011034	TSN 55 I	15-55 N.m	10-40 lbf.ft	3/8	330	0.9
011054	TSN 125 I	40-125 N.m	30-90 lbf.ft	1/2	450	1.5



- The **Standard I Torque Screwdrivers** incorporate slipping technology, eliminating overtightening
- Smooth reset action reduces operator fatigue
- This tool can only be **supplied factory preset**
- Designed and manufactured to comply with the requirements of BS EN ISO 6789:2003
- Tools come complete with a Certificate to BS EN 60900:2004 (Live working hand tools for use up to 1000V ac and 1500 V dc)
- Accuracy +/- 6% of setting
- Accessories available – see page 56

Order Code	Model	Range		Drive	mm	kg
		ISO	Imperial			
015720	Standard I	6-500 cN.m	0.5-44 lbf.in	1/4	165	0.4



## 50V Insulated Tools

Tools for use in low voltage applications

- The **TBN I** range of **Torque Handles** utilises a 20° breaking action that reduces the possibility of overtightening by clearly indicating to the operator when the preset torque has been achieved
- Designed for use in uninterrupted power supply and other battery applications where protection up to 50V is required
- Comes complete with 1/4" drive fine tooth ratchet
- Double layer PVC insulation provides protection against low voltage shorting
- These tools can only be **supplied factory preset**
- Low voltage TSN models also available
- Designed and manufactured to exceed the requirements of ISO 6789:2003
- Repeatability +/- 6% of set torque
- A range of insulated sockets available - [salesandrepairs@torqueleader.co.uk](mailto:salesandrepairs@torqueleader.co.uk)



Order Code	Model	Range		Drive	mm	g
		ISO	Imperial			
011108	TBN 2 50V	0.2-2 N.m	1.8-18 lbf.in	1/4	105	168
011208	TBN 10 I 50V	1.0-10 N.m	9-89 lbf.in	1/4	105	168
011062	TSN 25 D 50V	3-25 N.m	2-18 lbf.ft	1/4	220	400
011072	TSN 25 A 50V	3-25 N.m	2-18 lbf.ft	1/4	220	400



## TCR Clicker Wrenches

Calibrated tools for Service and Repair



Interchangeable 1/4" and 3/8" square drive



1/2" push through square drive

- TCR Clicker Wrenches are adjustable by the user. The torque setting can be easily read off the micrometer scale. A click can be heard and felt when the set torque is reached
- Adjustment lock mechanism prevents accidental adjustment during operation
- Robust construction, designed to operate in any environment, from the Oil and Gas Industries to Automotive Repair
- The TCR has a push through ratchet for torque tightening clockwise and anticlockwise
- These tools have been designed and manufactured to exceed the requirements of ISO 6789:2003
- Accuracy +/- 6% of reading for TCR 5 and +/- 4% of set torque for all other models
- ISO 6789:2003 classification 2A
- Accessories available - see pages 54 and 55

Ratchet Size	Order Code
1/4"	024000
3/8"	024010
1/2"	024020

Order Code	Model	← Calibrated Range →		Imperial	Drive	mm	kg
		ISO	SI				
024060	TCR 5 D	1-5 N.m	0.025 N.m	0.75-3.7 lbf.ft	1/4"	220	0.30
024080	TCR 25 D Slim	2-25 N.m	0.1 N.m	2-19 lbf.ft	1/4"	280	0.45
024090	TCR 220 D	-	-	20-220 lbf.in	1/4" + 3/8"	280	0.45
024125	TCR 50 Slim	5-50 N.m	0.25 N.m	5-37.5 lbf.ft	3/8"	330	0.55
024140	TCR 100	10-100 N.m	0.5 N.m	10-75 lbf.ft	1/2"	395	0.90
024160	TCR 200	20-200 N.m	1 N.m	20-150 lbf.ft	1/2"	485	1.1
024180	TCR 300	60-300 N.m	1 N.m	50-220 lbf.ft	1/2"	575	1.4
024200	TCR 400	75-400 N.m	1 N.m	60-300 lbf.ft	1/2"	665	1.6
024220	TCR 550	100-550 N.m	1 N.m	75-400 lbf.ft	3/4"	960	3.8
024240	TCR 750	140-750 N.m	1 N.m	100-550 lbf.ft	3/4"	1240	4.8



## TCS & TCP Clicker Wrenches

Clicking tools for use with wrench fittings

- TCS Clicker Wrenches** are adjustable by the user. The torque setting can be easily read off the micrometer scale. A click can be heard when the preset torque is reached
- An adjustment lock mechanism prevents accidental adjustment during use
- Designed and manufactured to exceed the requirements of ISO 6789:2003
- Accuracy +/- 4% of set torque
- ISO 6789:2003 classification 2A
- Accessories available – see page 54



Order Code	Model	← Calibrated Range →		Drive	mm	kg
		ISO	Imperial			
024305	TCS 25 Slim	2-25 N.m	0.1 N.m	16	280	0.5
024325	TCS 50 Slim	5-50 N.m	0.25 N.m	16	330	0.6
024340	TCS 100	10-100 N.m	0.5 N.m	16	375	0.6
024360	TCS 200	20-200 N.m	1 N.m	16	465	0.8
024380	TCS 300	60-300 N.m	1 N.m	16	565	1.2
024400	TCS 400	75-400 N.m	1 N.m	16	650	1.5

- TCP Clicker Wrenches** are designed for accuracy and repeated torque application. Ideal for Production use. There is no scale and the tool must be preset on a Torque Analyser
- A click can be heard and felt when the preset torque is reached
- Lightweight with robust construction
- Designed and manufactured to exceed the requirements of ISO 6789:2003
- Repeatability +/- 4% of set torque
- Accessories available – see page 54



Order Code	Model	← Range →		Drive	mm	kg
		ISO	Imperial			
024420	TCP 25 S	2-25 N.m	2-19 lbf.ft	16	180	0.21
024440	TCP 50 S	5-50 N.m	5-37.5 lbf.ft	16	240	0.27
024460	TCP 85 S	15-85 N.m	10-75 lbf.ft	16	320	0.34
024480	TCP 200 S	20-200 N.m	20-150 lbf.ft	16	400	0.75



# Apply

## Signal Transmission Options

For greater control over the production process



### Signal Transmission Options

The Torqueleader range of **TBN, TSN, TSP** and **STB**

Production tools can be supplied with a choice of **two options** for transmitting a signal when a tightening event has taken place. Each time the operator uses the tool a signal is sent or can be recorded, offering greater control over the production process

➤ **Switch and Cable Tools** use a mechanical switch which is operated each time the wrench achieves its set torque. The switch is connected via cable to the Production Line Control System. This option is a cost effective system for Production environments as well as offering guaranteed torque control

➤ **TALS-2** is a wireless torque application monitoring system operating on 433 MHz FM (license exempt). This system offers the reliability of the switch system but without the restriction of tool cables. Compatible with most Production Line Control Systems and a cost effective way of monitoring torque application during the production process

## Signal Transmission Options for Production Process

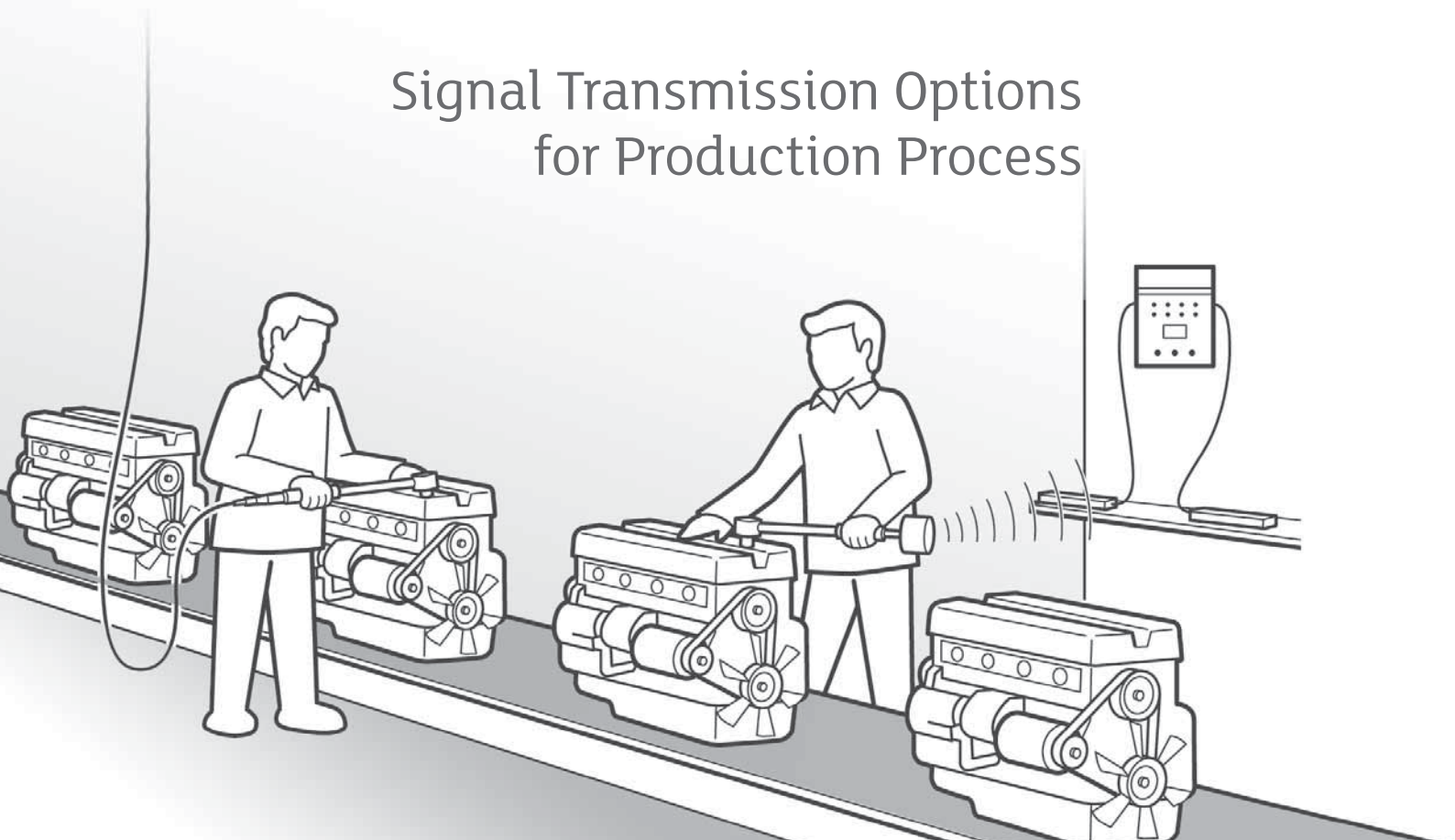



## Switch Operated Signal System

Designed to provide fail safe tightening

- ▶ The **TBN, STB and TSN Switch Tools** send a signal to a remote monitoring device when the preset torque has been applied, providing greater control over the production process
- ▶ The TBN, STB and TSN Switch tools are based on the well established Torqueleader technology and bring all the benefits of reducing the risk of overtightening
- ▶ Switch tools can be integrated into most Production Line Control Systems, as well as operate counters and gate switches
- ▶ Torqueleader Switch tools come complete with a 6m cable featuring a cable strain relief system
- ▶ A Signal Delay Unit (SDU) is available as an optional interface between the Switch tool and Production Line Control Systems. Its function is to prolong the signal duration to guarantee communication



**Switch Tools (Sw)** - supplied complete with switch and cable

Order Code	Model	Range		Drive
		ISO	Imperial	
056093	TSP 5 Sw	1-5 N.m	10-45 lbf.in	1/4
056103	TSP 10 Sw	2-10 N.m	20-90 lbf.in	1/4
011003	TSN 25D Sw	3-25N.m	2-18 lbf.ft	1/4
011013	TSN 25A Sw	3-25 N.m	2-18 lbf.ft	3/8
011033	TSN 55 Sw	15-55 N.m	10-40 lbf.ft	5/8
011053	TSN 125 Sw	40-125 N.m	30-90 lbf.ft	1/2
011103	TBN 2 Sw	0.2-2.0 N.m	1.8-18 lbf.in	8
011203	TBN 10 Sw	1-10 N.m	9-89 lbf.in	8
050003	TBN 25 Sw	5-25 N.m	4-18 lbf.ft	16
050013	TBN 25 G Sw	5-25 N.m	4-18 lbf.ft	9x12
050103	TBN 65 Sw	10-65 N.m	7-48 lbf.ft	16
050113	TBN 65 G Sw	10-65 N.m	7-48 lbf.ft	9x12
050203	TBN 135 Sw	20-135 N.m	15-100 lbf.ft	16
050213	TBN 135 G Sw	20-135 N.m	15-100 lbf.ft	9x12
052003	STB 35 Sw	7-35 N.m	5-25 lbf.ft	16
052013	STB 35 G Sw	7-35 N.m	5-25 lbf.ft	9x12
052103	STB 70 Sw	14-70 N.m	14-51 lbf.ft	16
052113	STB 70 G Sw	14-70 N.m	14-51 lbf.ft	9x12



Single Delay Unit (SDU)

Order Code	Description
C12870	Signal Delay Unit
B25900	Universal Switch Module
D94402	Straight Cable
D94406	Coiled Cable



## TALS-2 Wireless Signal System

Designed to provide fail safe tightening



- **TALS-2** is a Wireless Signal System that sends a signal to an external monitoring device when a preset torque has been applied. This provides greater control over the production process
- TALS-2 is compatible with most Production Line Control Systems as well as operate counters and gate switches
- Two way communication between the wrench and user interface box via remote transceiver nodes (which can be positioned close to the works area) provide reliable signal communication
- Up to four Torqueleader Wireless wrenches can be monitored simultaneously from a single user interface box
- Wrench transceivers are designed to resist fluid and dust ingress, have long battery life and are supplied with a protective cover
- The TALS-2 system has RS232 connectivity



TALS-2 Core System

### Radio Frequency Tools (RF) - supplied with TALS-2 Transceiver

Order Code	Description
051000	TALS-2 Core System*
051040	TALS-2 Node Transceiver
P29240	TALS-2 Node Cables
051060	Wrench Transceiver
P29640	Wrench Transceiver Batteries
P30420	TALS-2 Power Supply
051080	Circuit Terminator

\*TALS-2 Core System includes - User interface box, two nodes & cables

Order Code	Model	Range		Drive
		ISO	Imperial	
056098	TSP 5 RF	1-5 N.m	10-45 lbf.in	1/4"
056108	TSP 10 RF	2-10 N.m	20-90 lbf.in	1/4"
011066	TSN 25D RF	3-25N.m	2-18 lbf.ft	1/4"
011076	TSN 25A RF	3-25 N.m	2-18 lbf.ft	3/8"
011086	TSN 55 RF	15-55 N.m	10-40 lbf.ft	3/8"
011096	TSN 125 RF	40-125 N.m	30-90 lbf.ft	1/2"
011101	TBN 2 RF	0.2-2.0 N.m	1.8-18 lbf.in	8
011201	TBN 10 RF	1-10 N.m	9-89 lbf.in	8
050002	TBN 25 RF	5-25 N.m	4-18 lbf.ft	16
050012	TBN 25 G RF	5-25 N.m	4-18 lbf.ft	9x/12
050102	TBN 65 RF	10-65 N.m	7-48 lbf.ft	16
050112	TBN 65 G RF	10-65 N.m	7-48 lbf.ft	9x/12
050202	TBN 135 RF	20-135 N.m	15-100 lbf.ft	16
050212	TBN 135 G RF	20-135 N.m	15-100 lbf.ft	9x/12
052002	STB 35 RF	7-35 N.m	5-25 lbf.ft	16
052012	STB 35 G RF	7-35 N.m	5-25 lbf.ft	9x/12
052102	STB 70 RF	14-70 N.m	14-51 lbf.ft	16
052112	STB 70 G RF	14-70 N.m	14-51 lbf.ft	9x/12



# Industrial Torque Wrenches & Rotary Torque Units

- Industrial Torque Wrenches have a calibrated scale
- The large break angle improves accuracy by reducing the possibility of overtightening
- Cam control mechanism gives a controlled break
- Robust construction makes the wrench ideal for use in demanding working conditions
- Accuracy +/- 4% of set torque
- ISO 6789:2003 classification 2A



Order Code	Model	← Calibrated Range →			Drive	mm	kg
		ISO	10 N.m	Imperial			
023500	3AR	100-500 N.m	10 N.m	70-350 lbf.ft	3/4	915	5.2
023520	4R	150-700 N.m	10 N.m	100-500 lbf.ft	3/4	1090	6.3
023530	4AR	200-800 N.m	10 N.m	150-600 lbf.ft	3/4	1140	6.4
023540	5R	300-1000 N.m	10 N.m	200-750 lbf.ft	3/4	1470	7.3
023560	5AR	700-1500 N.m	20 N.m	550-1000 lbf.ft	3/4	1470	10.4

- The Rotary Torque Units are designed to be used **in line** to limit torque. Ideal for use in both manual and certain power driven applications
- Mechanism slips free when preset torque is reached, eliminating overtightening
- Robust construction designed for high volume production
- Repeatability +/- 6% of set torque
- ISO 6789:2003 classification 2F



Order Code	Model	← Range →		Speed	Input Drive	Output Drive
		N.m	lbf.in			
018100	RTU 170	10-170 cN.m	0.9-15 lbf.in	0-500	3/8	3/8
018120	RTU 170 HEX	10-170 cN.m	0.9-15 lbf.in	0-500	1/4	1/4
018200	RTU 450	1-4.5 N.m	9-40 lbf.in	0-500	3/8	3/8
018220	RTU 450 HEX	1-4.5 N.m	9-40 lbf.in	0-500	1/4	1/4
018300	RTU 1000	4-10 N.m	36-88 lbf.in	0-250	3/8	3/8
018320	RTU 1000 HEX	4-10 N.m	36-88 lbf.in	0-500	1/4	1/4



# Torque Tool Kits

## CUSTOM TOOL KIT DESIGNS

Torqueleader have been successful in fulfilling bespoke tool kit requirements. While based on Torqueleader's core product range, additional standard and custom designed tooling is often manufactured, sourced and supplied as part of the kit.



### SERVICE AND REPAIR TOOL KIT

- ▶ A kit supplied to an OEM manufacturer to accompany their product into the field for Service and Repair
- ▶ This contains Torqueleader Oneway (O/W) Torque Screwdrivers and also a pair of Gedore pliers

### FIELD SERVICE TOOL KIT

- ▶ This contains both Torqueleader and outsourced tools, supplied in a rugged case for maintaining a vehicle based electrical installation



### LIFE JACKET KIT

- ▶ Torqueleader worked in conjunction with the customer to design a kit of special tools for servicing life jackets
- ▶ The kit includes a custom designed strap wrench fitted to a TBN 10 and a special Schrader valve adaptor

### AIR CONDITIONING KIT

- ▶ An installation kit for the Air Conditioning industry containing an adjustable torque wrench with a range of interchangeable wrench fittings, selected to suit all common pipe joints





# Introduction to Torque Calibration

## THE IMPORTANCE OF TORQUE CALIBRATION

Regular Torque Tool calibration guarantees repeated accuracy and adherence to International Standards. Calibration also ensures torque equipment is operating to peak performance and can highlight potential tooling problems before they arise perhaps due to tool wear or broken components.

## TORQUELEADER OFFERS TWO TYPES OF TORQUE ANALYSER

- ▶ **Mechanical Analysers** offer the user a low cost, robust and easy to use device, that is designed to set and calibrate low range Hand Torque Tools. These Analysers will give many years of accurate and reliable service
- ▶ **Electronic Analysers** are highly accurate, reliable and easy to use. These Analysers can offer the user much more than torque calibration. Our modern range of digital torque calibration equipment can allow the user to download test results, test power tools, select different units of measurement and carry out calibration beyond the scope of mechanical calibration devices

## CALIBRATION ANALYSER SELECTION GUIDE

Torque Calibration Analysers	Features					
	Screwdriver Testing	Wrench Testing	Powered Tool Testing	Memory Capability	PC Download Capability	Generates Certificate
MTP	✓					
MTS	✓	✓				
QTC	✓	✓			✓	
ET-cal Compact	✓	✓	✓		✓	
ET-cal	✓	✓			✓	
PETA	✓	✓	✓	✓	✓	✓





## MTP & MTS Torque Calibration Analysers

Mechanical Screwdriver testers



- The **MTP 10 Analysers** are ideal for low range torque testing in Workshops, Calibration Laboratories and on Production lines
- A bi-directional mechanism allows the checking of both clockwise and anticlockwise Torque Tools
- Easy to read dual scale, dial mirror and spirit level confirm the accuracy of readings by eliminating parallax and pendulum errors
- Supplied with Calibration Certificate traceable to National Standards
- Accuracy of +/- 2% of reading

Order Code	Model	← Calibrated Range →				Drive	kg
		ISO	Imperial	Imperial	ISO		
058100	MTP 10	0-10 cN.m	0.5 cN.m	0-14 ozf.in	1ozf.in	$\frac{1}{8}$	0.98



- The **MTS Analysers** have a robust ergonomic design and includes an angled dial for ease of reading
- Innovative spindle lock system eliminates the need for tool removal when adjusting the tool's torque setting
- Slave pointer records peak torque and limit pointers can be used to mark preset limits
- Reversible drive adaptors provide two drive options per model
- Supplied with Calibration Certificate traceable to National Standards
- Accuracy +/- 2% of reading

Order Code	Model	← Calibrated Range →				Drive	kg
		ISO	Imperial	Imperial	ISO		
058110	MTS 35	7-35 cN.m	0.5 cN.m	10-50 ozf.in	0.5 ozf.in	$\frac{1}{8} + \frac{1}{4}$	3.2
058120	MTS 130	26-130 cN.m	2 cN.m	36-180 ozf.in	2 ozf.in	$\frac{1}{8} + \frac{1}{4}$	3.2
058130	MTS 400	0.8-4 N.m	0.05 N.m	7-36 lbf.in	0.5 lbf.in	$\frac{1}{8} + \frac{1}{4}$	3.2
058140	MTS 1200	2.4-12 N.m	0.2 N.m	24-120 lbf.in	2 lbf.in	$\frac{1}{4} + \frac{3}{8}$	3.2
058150	MTS 2500	5-25 N.m	0.5 N.m	44-220 lbf.in	5 lbf.in	$\frac{1}{4} + \frac{3}{8}$	3.2



## QTC Torque Calibration Analysers

Robust workshop digital torque testers

- The **QTC Analysers** are rugged, reliable and easy to use for Hand Torque Tools
- Three models cover a wide torque range and are ideal for Workshop and Repair environments
- Clear digital display
- Operates in a clockwise direction for checking and presetting torque wrenches
- User selectable units of measurement in N.m or lbf.ft
- The QTC has an angled display for ease of reading
- Each model has two square drive options
- Supplied with RS232 cable for realtime data download
- Input voltage 110 to 240 volts
- Accuracy of +/- 1% of reading



Order Code	Model	← Calibrated Range →				Drive	kg
		ISO	Resolution	Imperial	Resolution		
035220	QTC 55	0.9-55 N.m	0.01 N.m	0.7-40 lbf.ft	0.01 lbf.ft	$\frac{1}{4} + \frac{3}{8}$	2.5
035210	QTC 320	9-320 N.m	0.1 N.m	7-236 lbf.ft	0.1 lbf.ft	$\frac{3}{8} + \frac{1}{2}$	2.5
035230	QTC 1100	90-1100 N.m	1 N.m	66-811 lbf.ft	0.1 lbf.ft	$\frac{1}{2} + \frac{3}{4}$	10.5



## ET-cal Compact Torque Calibration Analysers

Robust digital torque tester



- ▶ The **ET-cal Compact Analysers** are a portable battery or mains powered torque tester for small hand and power tools, ideal for Calibration Laboratories and Production lines
- ▶ Designed to test torque in both clockwise and anticlockwise directions
- ▶ Features a large display and built in transducer
- ▶ User modes include Track or Peak with multiple units of measurement
- ▶ Non-impact power tool testing feature, including four low pass filter selections and a rundown adaptor with three interchangeable springs to allow simulation of **actual** joints
- ▶ RS232 interface provided to download readings for easy SPC analysis
- ▶ Accuracy +/- 0.5% of readings from 20-100% of full scale.  
+/- 1% of reading from 10-20% of full scale



Order Code	Model	← Calibrated Range →		Drive	kg
		ISO	Imperial		
035270	ET-cal 1	0.1-1 N.m	0.8-8.8 lbf.in	$\frac{3}{8}$ + $\frac{1}{4}$	2
035280	ET-cal 5	0.5-5 N.m	4.4-44 lbf.in	$\frac{3}{8}$ + $\frac{1}{4}$	2
035290	ET-cal 10	1-10 N.m	8.8-88 lbf.in	$\frac{3}{8}$ + $\frac{1}{4}$	2
035295	ET-cal 17	1.7-17 N.m	15-150 lbf.in	$\frac{3}{8}$ + $\frac{1}{4}$	2



## ET-cal Torque Calibration Analysers

Robust digital torque testers

- ▶ The ET-cal Microprocessor Controlled Torque Analysers are for calibrating and presetting medium to large Torque Wrenches (up to 3150 N.m)
- ▶ User modes include Peak, First Peak and Final Peak. Multiple units of measure include N.m, cN.m, lbf.ft and lbf.in
- ▶ A detachable display enables the user to position the screen for better visibility when calibrating longer Torque Wrenches
- ▶ Supplied with RS232 interface to allow realtime download of peak torque value and unit of measurement
- ▶ Robust design can be mounted in horizontal and vertical planes
- ▶ Modular design offers a variety of options to the user including, different size transducers and accessories which can be purchased separately
- ▶ Accuracy +/- 1% of reading, +/-1 digit



Order Code	Model	← Calibrated Range →		Drive
		ISO	Imperial	
035300	ET-cal 15 Core System*	0.5-15 N.m	5-130 lbf.in	$\frac{1}{4}$
035310	ET-cal 100 Core System*	4-100 N.m	3-74 lbf.ft	$\frac{1}{4} + \frac{3}{8} + \frac{1}{2}$
035320	ET-cal 500 Core System*	20-500 N.m	15-370 lbf.ft	$\frac{3}{8} + \frac{1}{2} + \frac{3}{4}$
035330	ET-cal 1000 Core system*	50-1000 N.m	37-740 lbf.ft	$\frac{3}{8} + \frac{1}{2} + \frac{3}{4}$
035340	ET-cal 3150 Core system*	300-3150 N.m	220-2325 lbf.ft	$1\frac{1}{2}$

\*The Core System includes: transducer, display module, display stand, cable (transducer to display stand), power supply, instructions and robust storage case.

Order Code	Model	← Calibrated Range →		Drive
		ISO	Imperial	
035360	ET-cal 15 XD Transducer	0.5-15 N.m	5-130 lbf.in	$\frac{1}{4}$
035370	ET-cal 100 XD Transducer	4-100 N.m	3-74 lbf.ft	$\frac{1}{4} + \frac{3}{8} + \frac{1}{2}$
035380	ET-cal 500 XD Transducer	20-500 N.m	15-370 lbf.ft	$\frac{3}{8} + \frac{1}{2} + \frac{3}{4}$
035390	ET-cal 1000 XD Transducer	50-1000 N.m	37-740 lbf.ft	$\frac{3}{8} + \frac{1}{2} + \frac{3}{4}$
035400	ET-cal 3150 XD Transducer	300-3150 N.m	220-2325 lbf.ft	$1\frac{1}{2}$
035420	Display Module			
035430	Display Stand & Cable			
035440	RS232 Cable (Transducer to PC)			



## Personal Electronic Torque Analysers

PC hosted Calibration System



- **PETA 4 USB** is the complete PC/Laptop hosted Torque Calibration Analyser ideal for Laboratory use
- Designed to interface a transducer with your PC/Laptop via a USB connector, therefore eliminating the need for a dedicated display
- Collect data, performs SPC analysis and displaying results directly into Microsoft Excel
- Produces Calibration Certificates to ISO 6789:2003 directly to MS word
- Virtually unlimited memory storage capacity via Torque Tool and transducers databases with password protection
- Operating modes include Track, Peak, First Peak and Power Tools testing modes
- Recalibration planning for Torque Tools has never been easier with automatic reminders being sent via Microsoft Outlook tasks
- Compatible with most industry standard mV/V transducer
- Range of transducer cables are available – call our Sales Hotline on **+44 (0) 1483 894476**

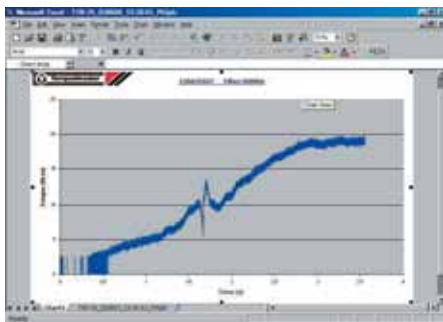

Power Tool Test



Control Chart



Distribution Curve

Order Code	Model
036160	PETA 4 USB System
036165	PETA USB Upgrade
036235	PETA Cable Upgrade
036246	Curly Cable - XB & XR Transducer
036251	Curly Cable - SDX Transducer
036256	Curly Cable - ETX Transducer

**Note:** The PETA CF2 card provides a highly accurate (to3ppm) stable excitation voltage and therefore the accuracy of PETA is dependent on the quality of transducer used. Typically this is +/- 0.5% of reading between 10% and 100% of full scale.



## Flange Mounted Transducers

Medium duty tools incorporating large dial

- ▶ The **Flange Mounted Transducers** incorporate mounting points for securely fixing the transducer to the working surface
- ▶ The transducer lead is also included and is fitted with a high quality Lemo® connector, suitable for attachment to the PETA system
- ▶ Rundown fixtures are included with transducers up to 150 N.m (100 lbf.ft) allowing joint simulation for Power Tool testing
- ▶ Supplied with UKAS Calibration Certificate
- ▶ Transducers are supplied with precision made square drive adaptors
- ▶ Additional bench mounting brackets are also available – call our Sales Hotline on **+44 (0) 1483 894476**

Rundown Fixture



Order Code	Model	Calibrated Range	Drive
036600	FMT 2	0.04-2 N.m	$\frac{1}{4}$
036610	FMT 10	0.5-10 N.m	$\frac{1}{4}$
036620	FMT 25	1.25-25 N.m	$\frac{1}{2} + \frac{3}{8}$
036630	FMT 150	7.5-150 N.m	$\frac{3}{8} + \frac{1}{2}$
036640	FMT 400	20-400 N.m	$\frac{1}{2} + \frac{3}{4}$
036650	FMT 1500	30-1500 N.m	$\frac{1}{2} + \frac{3}{4}$

Order Code	Model	Suitable For
020680	Small Mounting Bracket	2 N.m - 400 N.m Transducers
020690	Large Mounting Bracket	150 N.m - 1500 N.m Transducers



## Static & Rotary Torque Transducers

For use with the PETA Torque Calibration System



- The **XB Static Transducers** are designed to ignore non-torsional forces
- For use with the PETA Torque Calibration System and ISO Torque Test Rigs
- Operate in both clockwise and anticlockwise directions
- Rundown nose assemblies and bench stands are also available
- Supplied with UKAS Certification of Calibration
- Accuracy +/- 0.5% of reading between 10 and 100% of full scale

Order Code	Model	Calibrated Range ISO	A Drive	B   mm	C   mm	Bench Stand	g
035710	XB1	0.1-1.0 N.m	1/4	79	36.5	020530	450
035720	XB 5	0.5-5 N.m	1/4	79	36.5	020530	450
035725	XB 10	1-10 N.m	1/4	79	36.5	020530	450
035730	XB 25	2.5-25 N.m	3/8	79	36.5	020535	450
035740	XB 50	5-50 N.m	3/8	79	36.5	020535	450
035750	XB 100	10-100 N.m	1/2	79	36.5	020545	450
035760	XB 500	50-500 N.m	3/4	118	54	020555	1500
035770	XB 1000	100-1000 N.m	1	118	54	020565	1600
035775	XB 2500	250-2500 N.m	1 1/2	117	95	020580	4600

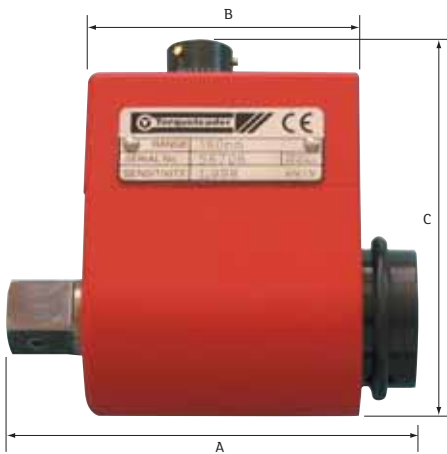

- The **XR Rotary Transducers** are designed for Calibration and Monitoring Powered Torque Tools including Impulse Power Tools
- Supplied with **In House** Certification of Calibration. UKAS Certificate available on request
- No **brush bounce** giving greater accuracy on Impulse Tool applications
- Calibrated to give industry standard 2mV/V output at maximum capacity
- Accurate to 0.3% of maximum torque applied

Order Code	Model	Calibrated Range ISO	Drive	Maximum RPM		A   mm	B   mm	C   mm	g
				Continuous	Intermittent				
036510	XR 2 HD	0.2 - 2 N.m	1/4	5000	11000	116	56	68	207
036520	XR 5 HD	0.5 - 5 N.m	1/4	5000	11000	116	56	68	207
036530	XR 20 HD	2 - 20 N.m	1/4	5000	11000	116	56	68	207
036540	XR 20 SD	2 - 20 N.m	1/4	5000	11000	71.5	56	71.5	196
036550	XR 75 SD	7.5 - 75 N.m	3/8	2500	10000	77	56	74	235
036560	XR 180 SD	18 - 180 N.m	1/2	2500	7600	87	58	82.5	425
036570	XR 500 SD	50 - 500 N.m	3/4	2000	5000	106	60	93.5	755
036580	XR 1400 SD	140 - 1400 N.m	1	1000	4400	125	64.5	104	1500



## SDX & ETX Electronic Transducer Screwdrivers & Wrenches

- The **SDX Transducer Screwdrivers** are the ideal tool for Quality Auditing or Tightening fasteners to a preset torque when connected to a PETA system
- Features include overload protection to prevent damage to the tool should the maximum torque be exceeded accidentally
- The ergonomic design makes this tool ideal for repetitive use
- Accuracy +/- 0.25% of full scale
- Accessories available – see pages 54 and 56



Order Code	Model	← Calibrated Range →		Drive	mm	g
		ISO	Imperial			
036320	SDX 100	12-110 cN.m	1-10 lbf.in	$\frac{1}{4}$	152	227
036340	SDX 550	60-560 cN.m	5-50 lbf.in	$\frac{1}{4}$	152	227

- The **ETX Transducer Wrenches** are ideal for **just move** and **break loose** Quality Audit Testing
- The ETX incorporates **QuickTec** technology which allows tool specific information to be downloaded into PETA or other compatible measurement and calibration devices
- Works with PETA and any industry standard mV/V monitoring system
- Non length dependent removing errors caused by user hand position
- Designed to torque in both clockwise and anticlockwise directions
- Accuracy exceeds +/- 1% applied torque
- Accessories available – see pages 54 and 55



Order Code	Model	← Calibrated Range →		Drive	mm	kg
		ISO	Imperial			
053980	ETX 10	1-10 N.m	20-90 lbf.in	$\frac{1}{4}$	215	0.25
054000	ETX 30	3-30 N.m	2-22 lbf.ft	$\frac{1}{4}$	215	0.25
054020	ETX 100	10-100 N.m	7-70 lbf.ft	$\frac{3}{8}$	450	0.65
054040	ETX 300	30-300 N.m	22-220 lbf.ft	$\frac{1}{2}$	665	1.1



## ISO 1500/90° & ISO-A Test Rigs

Ergonomic and versatile tools with clear display



- The **ISO 1500/90° Test Rigs** are designed with precision in mind. The rig simulates torque application conditions while eliminating the **human element** from testing
- 1400:1 gearbox allows high torque to be applied with the minimum of operator effort
- Designed to be used in conjunction with XB Static Torque Transducers and the PETA system
- Fully adjustable to suit size of Torque Wrench being tested
- The ISO 1500/90° Rig supplied with square drive adaptors and collars to suit the Torqueleader range of XB Static Transducers
- This rig is designed to calibrate Torque Wrenches in accordance with International Standards ISO 6789:2007
- Maximum capacity 1107 lbf.ft/1500 N.m  
Maximum tool length 1350mm
- Transducer and Read Out not included

Order Code	Model
014300	ISO 1500/90°



- The **ISO-A Test Rigs** enable quick and easy Torque Screwdriver calibration and presetting, independent of **human** influence, eliminating transducer side and end load factors
- Designed to work in conjunction with a range of Electronic Torque Analysers including ET-cal and PETA - see pages 44, 45 and 46
- Supplied with drive adaptors and adjusting keys to suit Torqueleader screwdriver models: TLS 0022, Micro, Minor, Standard, TLS 1360, Quickset and TT
- Maximum torque capacity 30 N.m. Maximum tool length 300mm
- Transducer and Read Out not included

Order Code	Model
014400	Torquemaster ISO-A Test Rig
D18204	ET-cal 15 Mounting Kit
A29170	Flange Mounted Transducer Mounting Kit*
014420	XB Mounting Kit

\*Suitable for ISO-A Test Rig



# Additional Torque Products

## Information on Torque Tool Accessories

Torqueleader stock a wide range of Accessories to complement our Torque Tools, enabling you to obtain everything you need for your application from one source. If you require Accessories not in our standard range please call our Sales Hotline **+44 (0) 1483 894476**

### HEXAGON KEY ADAPTORS

- ▶ In response to customer demand, Torqueleader have introduced two easy to use adaptors that allow a range of hexagon keys to be used with the TBN 2 and TBN 10
- ▶ The two adaptors allow the use of hexagon keys from 1.0 mm to 5.0 mm (see page 53) and are interchangeable using a simple locking screw arrangement
- ▶ As the TBN 2 and 10 are length dependent, factory fitted hexagon keys will have a cut length of 25 mm from centre of hexagon drive to the rear internal face of the adaptor (see diagram - top right), to enable the tools to be calibrated and/or preset
- ▶ Tools factory set and supplied with a hexagon key will come with a Certificate of Calibration. Tools that are supplied without a hexagon key will need to be preset to the actual length of the hexagon key used. Please call our Sales Hotline for more information

**NEW  
Product for  
2010**





# Accessories

## Additional Torque Products

Accessories to complement Torqueleader tools

Hanging Loop End Caps



- ▶ The **Hanging Loop End Caps** are designed for use with TSN, TSP and TBN wrenches
- ▶ Enables the tools to be used with a lanyard or tool balance
- ▶ Not suitable for use with Sw or RF wrenches

Order Code	Model
B34872	TBNS 2, TBNS 10, TSP5/45 & TSP10/90
B34882	TBN 25 & TSN 25
B34892	TSN 55
B34902	TSN 125 TBN 65 & TBN 135

Hanging Loops



**NEW**  
Product for  
**2010**

- ▶ The **Hanging Loops** are designed for use with Switch tools

Order Code	Model	Colour
B37582	Hanging Loop Switch tools	Red

PVC Grips



- ▶ Easy to fit **PVC Grips** designed to improve user comfort and grip
- ▶ Tool colour coding, serial numbers and recalibration dates can be seen clearly through the transparent grips
- ▶ Up to 50% less operator effort in applying same torque
- ▶ Lubricant available for easy fitting of grips

Order Code	Model
P19030	Minor Grip
P19040	Standard Grip
A90220	P.80 Lubricant 100ml

TSN Head Covers



- ▶ The **TSN Head Covers** protect and fit the heads of the TSN range of wrenches
- ▶ Protects the work piece from accidental damage from the tool during use
- ▶ Ideal for Production areas where easily damaged materials are used

Order Code	Model
A29420	TSN 25 Head Cover
B28080	TSN 55 Head Cover
B28090	TSN 125 Head Cover



## Torque Wrench End Fittings

Accessories to complement Torqueleader tools

### TBN 2 & 10

Integral Captive Pin Fitting Type



Metric Size A/F	Open End Order Code	Ring End Order Code	Flared End Order Code	Setting Adaptor Order Code
3.2	012000	012250	–	012750
4	012005	012255	–	012755
5	012010	012260	–	012760
5.5	012015	012265	–	012765
6	012020	012270	–	012770
7	012025	012275	–	012775
8	012030	012280	012505	012780
9	012035	012285	012510	012785
10	012040	012290	012515	012790
11	012045	012295	012520	012795
12	012050	012300	012525	012800
13	012055	012305	012530	012805
14	012060	012310	012535	012810
15	012065	012315	012540	012815
16	012070	012320	012545	012820
17	012075	012325	012550	012825
18	012080	012330	–	012830
19	012085	012335	012555	012835
20	012090	012340	–	012840
21	012095	012345	–	012845
22	012100	012350	012560	012850
23	012105	012355	–	012855
24	012110	012360	012565	012860
25	012115	012365	–	012865

### TBNS 2 & 10

8mm Spigot Type



Metric Size A/F	Open End Order Code	Ring End Order Code	Flared End Order Code	Set With
3.2	049000	049250	–	A29071
4	049005	049255	–	A29071
5	049010	049260	–	A29071
5.5	049015	049265	–	A29071
6	049020	049270	–	A29071
7	049025	049275	–	A29071
8	049030	049280	049505	A29071
9	049035	049285	049510	A29071
10	049040	049290	049515	A29071
11	049045	049295	049520	A29071
12	049050	049300	049525	A29071
13	049055	049305	049530	A29071
14	049060	049310	049535	A29071
15	049065	049315	049540	A29071
16	049070	049320	049545	A29071
17	049075	049325	049550	A29071
18	049080	049330	–	A29071
19	049085	049335	049555	A29071
20	049090	049340	–	A29071
21	049095	049345	–	A29071
22	049100	049350	049560	A29071
23	049105	049355	–	A29071
24	049110	049360	049565	A29071
25	049115	049365	–	A29071

Imperial Size A/F	Open End Order Code	Ring End Order Code	Flared End Order Code	Setting Adaptor Order Code
5/32	012150	012400	–	012875
3/16	012155	012405	–	012880
7/32	012160	012410	–	012885
1/4	012165	012415	012600	012890
5/16	012175	012420	012605	012900
3/8	012185	012425	012610	012910
7/16	012195	012430	012615	012920
1/2	012200	012435	012620	012925
9/16	012205	012440	012625	012930
5/8	012210	012445	012630	012935
11/16	012215	012450	–	012940
3/4	012220	012455	012635	012945
13/16	012225	012460	–	012950
7/8	012230	012465	012640	012955
15/16	012235	012470	–	012960
1"	012240	012475	012645	012965

Imperial Size A/F	Open End Order Code	Ring End Order Code	Flared End Order Code	Set With
5/32	049150	049400	–	A29071
3/16	049155	049405	–	A29071
7/32	049160	049410	–	A29071
1/4	049165	049415	049600	A29071
5/16	049175	049420	049605	A29071
3/8	049185	049425	049610	A29071
7/16	049195	049430	049615	A29071
1/2	049200	049435	049620	A29071
9/16	049205	049440	049625	A29071
5/8	049210	049445	049630	A29071
11/16	049215	049450	–	A29071
3/4	049220	049455	049635	A29071
13/16	049225	049460	–	A29071
7/8	049230	049465	049640	A29071
15/16	049235	049470	–	A29071
1"	049240	049475	049645	A29071



Hex Adaptor  
Order Code: A37610 1.0 - 2.0mm  
A37620 2.5 - 5.0mm



TBN Setting Adaptor  
For Order Codes - see tables above



TBNS 2 & 10 8mm Spigot Type  
1/4\" Fixed Square Drive  
Order Code: A29070 20mm Centres  
A29071 25mm Centres  
A29072 30mm Centres



TBN 2 & 10 Integral Captive Pin Fitting Type  
1/4\" Ratchet Square Drive  
Order Code: A73640 27mm Centres



Adaptor Ring  
For making welded spanners  
Order Code: A29010 11 mm long  
A29011 16 mm long  
A29012 20 mm long



TBNS 2 & 10 8mm Spigot Type  
1/4\" Ratchet Square Drive  
Order Code: A28990 27mm Centres



# Accessories

## Adaptors & End Fittings

Accessories to complement Torqueleader tools

### TBN 25, 65, 135 & 200, TCS & TCP Ranges 16mm Spigot Type



Metric Size A/F	Open End Order Code	Ring End Order Code	Flared End Order Code
7mm	026020	027220	028190
8mm	026040	027240	028200
9mm	026060	027260	028210
10mm	026080	027280	028220
11mm	026100	027300	028240
12mm	026120	027320	028260
13mm	026140	027340	028280
14mm	026160	027360	028300
15mm	026180	027380	028320
16mm	026200	027400	028340
17mm	026220	027420	028360
18mm	026240	027440	028380
19mm	026260	027460	028400
20mm	026280	027480	028420
21mm	026300	027500	028440
22mm	026320	027520	028460
23mm	026340	027540	028480
24mm	026360	027560	028500
25mm	026380	027580	—
26mm	026400	027600	—
27mm	026420	027620	028520
30mm	026440	—	—
32mm	026460	—	—

Imperial Size A/F	Open End Order Code	Ring End Order Code	Flared End Order Code
5/16	026620	027720	—
3/8	026640	027740	028600
7/16	026650	027750	028620
1/2	026660	027760	028640
9/16	026680	027780	028660
5/8	026690	027790	028680
11/16	026700	027800	028700
3/4	026710	027810	028710
13/16	026720	027820	028720
7/8	026740	027840	028740
15/16	026750	027850	028750
1"	026760	027860	028760
1 1/16"	026770	027880	028770
1 1/8"	026780	027900	028780
1 3/16"	026800	027920	028800
1 1/4"	026820	—	—



Blank End Fitting  
Available to customers wishing to make special spanner end attachments.

Order Code A55230



Square Drive

Order Codes:  
1/8" - 029040  
1/2" - 029060



Ratchet Head Square Drive

Order Codes:  
1/8" - 029010  
1/2" - 029030

### Hexagon Key Adaptors

Insert Bit Hexagon Key Adaptors to be used with 1/4" AF Hexagon Holder FSHA

Order Code	Type	Size A/F	O/A Length
030300	IB 093	3/32"	1"
030310	IB 109	7/64"	1"
030320	IB 125	1/8"	1"
030330	IB 141	9/64"	1"
030340	IB 156	5/32"	1.3"
030360	IB 187	3/16"	1.3"
030380	IB 281	7/32"	1.3"
030400	IB 250	1/4"	1.3"
030410	IB 312	5/16"	1.2"
030100	IB 1.5	1.5mm	25mm
030120	IB 2	2mm	33mm
030140	IB 2.5	2.5mm	33mm
030160	IB 3	3mm	33mm
030180	IB 4	4mm	33mm
030200	IB 5	5mm	33mm
030220	IB 6	6mm	33mm
030240	IB 7	7mm	31mm
030260	IB 8	8mm	31mm

### Integral 1/4" Square Drive Hexagon Key Adaptors

Order Code	Type	Size A/F	O/A Length
B1607A	G2	.035"	1.36"
B1607B	G3	.050"	1.36"
B1607C	G4	.062"	1.36"
B1607D	G5	5/64"	1.36"

### Convertors

For changing from one square drive to another.

Order Code	Type
031320	DSAP 1/4" Sq. socket x 3/8" Sq. plug
031300	DPAS 3/8" Sq. socket x 1/4" Sq. plug
031340	ASEP 3/8" Sq. socket x 1/2" Sq. plug
031360	APES 1/2" Sq. socket x 3/8" Sq. plug
031380	ESHP 1/2" Sq. socket x 3/4" Sq. plug
031400	EPHS 3/4" Sq. socket x 1/2" Sq. plug
031420	HSGP 3/4" Sq. socket x 1" Sq. plug
031440	HPGS 1" Sq. socket x 3/4" Sq. plug

Socket



Plug

### Socket Blanks

For manufacturing special extensions for use with square drive tools. Material 817 M40(EN 24).

Order Code	Type	A	B	C
A15720	SB2	1/4"	5/8"	7/8"
A16200	SB3	3/8"	13/16"	11/8"
A16210	SB4	1/2"	1"	11/4"
A14790	SB5	3/4"	1 1/2"	25/16"
A14800	SB6	1"	2"	29/16"





## Sockets

Accessories to complement Torqueleader tools

### Insulated Sockets

1/4" in Drive		3/8" in Drive		1/2" in Drive	
A/F Size	Order Code	A/F Size	Order Code	A/F Size	Order Code
8 mm	B9066C				
10 mm	B9066D	10 mm	B9067D		
11 mm	B9066E	11 mm	B9067E		
12 mm	B9066F	12 mm	B9067F		
13 mm	B9066G	13 mm	B9067G	13 mm	B9069G
		14 mm	B9067H	14 mm	B9069H
		16 mm	B9067I	16 mm	B9069I
		17 mm	B9067J	17 mm	B9069J
		18 mm	B9067K	18 mm	B9069K
		19 mm	B9067L	19 mm	B9069L

Insulated Sockets



**NEW**  
Product for  
**2010**

### Nut Sockets

1/4" Square Drive Nut Sockets All Hexagon Form

Order Code	Type	Size A/F
031100	NS 8BA	.0152"
031120	NS 7BA	.172"
031140	NS 6BA	.193"
031160	NS 5BA	.220"
031180	NS 4BA	.248"
031200	NS 3BA	.282"
031220	NS 2BA	.324"
031240	NS 1BA	.365"
031260	NS 0BA	.413"
030800	NS 187	3/16"
030820	NS 219	7/32"
030840	NS 234	15/64"
030860	NS 250	1/4"
030880	NS 266	17/64"
030900	NS 281	9/32"
030920	NS 312	5/16"
030940	NS 344	11/32"
030960	NS 375	3/8"
030980	NS 437	7/16"
031000	NS 500	1/2"
030500	NS 4	4mm
030520	NS 4.5	4.5mm
030540	NS 5	5mm
030560	NS 5.5	5.5mm
030580	NS 6	6mm
030600	NS 7	7mm
030620	NS 8	8mm
030640	NS 9	9mm
030660	NS 10	10mm
030680	NS 11	11mm
030700	NS 12	12mm
030720	NS 13	13mm
030740	NS 14	14mm

Nut Sockets





# Accessories

## Screwdriver Accessories

Accessories to complement Torqueleader tools

### Inline Freewheel Adaptor



### Inline Freewheel Adaptor

- Specially designed for use with 1/4" FH Torque Screwdrivers
- Transmits torque in one direction and **freewheels** in the opposite direction, helping absorb unwanted shock loads
- Roller clutch for minimal backlash and drag

Order Code	Model	Torque	Freewheel
A8842R	FWA-R	Clockwise	Anticlockwise
A8842L	FWA-L	Anticlockwise	Clockwise

### 1/4" AF Hexagon Shank



### Torqueleader Screwdriver Accessories

- 1/4" AF Hexagon Shank Bits and Blades for use with all 1/4" FH Screwdrivers

Order Code	Type	Length	Size
026620	Phillips No. 0	25mm	No. 0
029610	Phillips No. 1	39mm	No. 1
029620	Phillips No. 2	39mm	No. 2
029640	Phillips No. 3	39mm	No. 3
029500	Pozidriv No. 0	25mm	No. 0
029520	Pozidriv No. 1	39mm	No. 1
029540	Pozidriv No. 2	39mm	No. 2
029560	Pozidriv No. 3	39mm	No. 3
029300	Blade 3	39mm	0.5 x 3mm
029320	Blade 4	39mm	0.5 x 4mm
029340	Blade 5.5	39mm	0.5 x 4mm
029360	Blade 6.5	39mm	1.2 x 6.5mm
029380	Blade 9	39mm	1.6 x 9mm
029740	Torx TX6	25mm	1.65
029760	Torx TX8	25mm	2.28
029770	Torx TX10	25mm	2.72
029780	Torx TX20	25mm	3.84

### Convertors/Adaptors



### Convertors/Adaptors

Order Code	Type	From	To	Length
A35640	FSHA	1/4" Female Sq.	1/4" Female Hex.	1 1/8"(30mm)
029200	EX-250-B2	1/4" Male Sq.	1/4" Male Hex.	2"(50mm)
A25420	MSHA	1/4" Male Sq.	1/4" Male Hex.	25mm

### Lock On T-Bar



Order Code: P25930

### Lock On T-Bar

- Removable **T-Bar** for larger models of screwdriver, provides extra leverage when required
- Lock on feature prevents accidental disengagement from the tool



## Special Extension Spanners

Accessories to overcome space and access limitations

### Special Extension Spanners

Where design or space limitations preclude the use of a dial wrench and a standard nut socket, special extension spanners can be manufactured to allow access

See illustrations for typical examples. When ordering these special attachments, please supply the following information:

- (A) Square drive size
- (B) A/F size of spanner end
- (C) End type - Ring, Open or Flared
- (E) Centred distance between the square drive and the spanner end fitting
- (T) Maximum Torque to be applied



#### Types of Ends

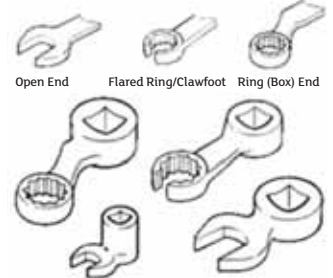

N.B. These are Artist's impressions only. Actual products may vary slightly in appearance. Note - where special shapes or offsets are required it is essential that a fully dimensioned drawing is supplied with your order. (Maximum torque should be stated).

$$TT = \frac{DR \times (L + E)}{L}$$

Where TT= True Torque  
 DR= Dial Reading  
 E= Extension Length  
 L= Effective Wrench Length



Model	All ADS Models		Models BDS80A/AS/E/ES		Other BDS Models		CDS Models		DDS Models		EDS Models	
-------	----------------	--	-----------------------	--	------------------	--	------------	--	------------	--	------------	--

Dimension L	mm	in	mm	in	mm	in	mm	in	mm	in	mm	in
	190	7.5	368	14.5	445	17.5	635	25	850	33.5	1727	68

Due to the low torque ranges and high accuracy it is recommended that Models ADS 4 & ADS 8 should not be used with extension spanners

### Extension Adaptors for ADS and BDS Wrenches

Torqueleader Extension Adaptors offer an alternative method of overcoming space and access limitations when using ADS and BDS Dial Measuring Torque Wrenches.

The Adaptors enable the use of a wide range of end fittings with 16mm Spigot, 9x12 German and Wedge fixings.

Each type of Adaptor is available with either a 3/8" or 1/2" female square drive and is easily fitted to the wrench male drive.

1. Attach the end fitting to the extension adaptor
2. Fit the assembly to the wrench square drive, taking care that it is "in-line" with the wrench body axis
3. Measure and note distance 'E' from centre of end fitting to wrench square drive

Adaptor Model	16mm Spigot		German 9x12 Cavity Fitting		Wedge Fitting	
Ratchet	3/8"	1/2"	3/8"	1/2"	3/8"	1/2"
Ordering Code	A96102	A96103	A96112	A96113	A96122	A96123

**Torqueleader** is a registered trademark of MHH Engineering Co. Ltd.  
Tannery Lane, Gosden Common, Bramley, Guildford, Surrey GU5 0AJ

**Sales Hotline:** +44 (0) 1483 894476

**Switchboard:** +44 (0) 1483 892772

**Facsimile:** +44 (0) 1483 898536

**Email:** salesandrepairs@torqueleader.co.uk

Torqueleader is a partner in the **GEDORE** Group

[www.torqueleader.com](http://www.torqueleader.com)



Printed on recycled material

All information in this document is correct at time of going to print 01/10.  
As part of its continuing development process Torqueleader reserves the right to alter specifications without prior notice.